

245 Consumers Road, Suite 400
Toronto, Ontario M2J 1R3
Canada
T +1.416.499.9000

www.jacobs.com

Subject	Hydraulic Analysis Study	Project Name	Mount Albert Water Supply System Upgrades
Attention	York Region	Project No.	CE731500
From	Jacobs		
Date	March 4, 2020		

1. Introduction

The Mount Albert community (located within the Town of East Gwillimbury) drinking water is supplied by wells owned and operated by the Regional Municipality of York (Region). The Mount Albert drinking water system has historically experienced aesthetic water quality issues related to iron and manganese as a result of the presence of these constituents in the source water. The Region has engaged Jacobs to undertake a Schedule 'B' Class Environmental Assessment (EA) to identify the best approach for resolving customer complaints with current water quality, meeting anticipated changes in manganese regulations and providing system redundancy and reliability (including optimization of system storage)

The purpose of this technical memorandum (TM) is to document the development of the Mount Albert water distribution system (WDS) hydraulic model, hydraulic and water quality calibrations and validations, and to identify opportunities for performance enhancement and optimization to be carried forward in the System Capacity Optimization Study.

2. Hydraulic Model Development

2.1 Review of Existing Model and Updates

The Town of East Gwillimbury provided Jacobs with a Draft Extended Period Simulation (EPS) InfoWater hydraulic model developed by WSP representing the Mount Albert water distribution system. The existing model was reviewed, and the following updates were made:

- Updating the Average Day Demand (ADD), and Maximum Day Demand (MDD)
- Development of an hourly diurnal demand pattern to apply to the demands during the EPS simulations
- Addition of system infrastructure (e.g. Well 3, Pump 3, and the 400 mm transmission main connecting Well 3 to the system)
- Various physical parameters (e.g. Ninth Line Elevated Tank storage-level curve, and operating levels, well facility pump curves, controls, and suction hydraulic grade-line)

After completing the indicated changes, the updated model files were submitted to the Region.

2.2 Historical Flow Data Analysis

2.2.1 Average and Maximum Day Demands

The Average Day Demands (ADD) extracted from the draft Mount Albert hydraulic model provided by the Town of East Gwillimbury (see Section 2.1), were compared to the ADD indicated in the *Class Environmental Assessment and Water Resource Exploration for Water Supply to the Community of Mount Albert, MMM, December 2006 (2006 EA)*, and *The Regional Municipality of York Water and Wastewater Master Plan, November 2016 (2016 MP)* and are summarized in Table 2-1.

Table 2-1. ADD and MDD from the Hydraulic Model, 2006 EA, and 2016 MP

Year	Hydraulic Model ADD / MDD (MLD)	2006 EA ADD / MDD (MLD)	2016 MP ADD / MDD (MLD)
2016	1.31 / NA	1.82 / 4.73	NA
2021	1.84 / NA	1.78 / 4.63	1.50 / 3.40
2026	1.86 / NA	1.75 / 4.55	NA
2031	1.87 / NA	NA	NA
2036	NA	1.92 / 4.99	NA
2041	1.86 / NA	NA	1.40 / 3.10
2051	NA	NA	1.40 / 3.10

Additionally, the historical data from the Mount Albert WDS SCADA system for the 2014 to 2018 period was analyzed to determine current and historical ADD and MDD. The values obtained are summarized in Table 2-2 and shown graphically in Figure 2-1.

Table 2-2. ADD and MDD from SCADA

Year	Total Water Demand (ML)	ADD (MLD)	MDD (MLD)	MDD (99 th Percentile) ¹ (MLD)	MDD Peaking Factor ²
2014	352	0.96	2.16	1.72	1.78
2015	381	1.05	2.43	1.98	1.89
2016	423	1.16	2.56	2.39	2.06
2017	384	1.05	3.33	2.53	2.41
2018	400	1.09	3.02	2.78	2.54
Average	388	1.06	2.50	2.28	2.14
Maximum	423	1.16	3.33	2.78	2.54

Notes:

1. The 99th percentile was used instead of the absolute maximum value to remove extraneous maximum day demands that may be caused by watermain breaks, fire flows, or flushing programs.
2. The MDD peaking factors are calculated using the ADD and the MDD (99th Percentile) values.



Figure 2-1 ADD and MDD from SCADA

Using the historical data summarized above, and projections from the 2016 MP, the ADD and MDD for each design year were determined, and are summarized in Table 2-3.

The 2016 model scenario was updated to reflect the actual demands recorded in the SCADA system over the last 5 years (see Table 2-2). The maximum annual average day demand from SCADA (1.16 MLD) was used for the 2016 ADD scenario. The maximum annual MDD peaking factor (99th percentile, rounded up) was used to calculate the MDD for the 2016 MDD scenario, based on the previously indicated ADD.

The Region provided ADD and MDD values for the future scenarios (2021 and 2041) from the 2016 MP. The ADD and MDD values for other future years (2026 and 2031) were interpolated from the values provided by the Region. Note that the MDD peaking factor declines over time, as calculated from the information received from the Region.

Table 2-3. Demands Used in the Hydraulic Model

Year	ADD (MLD)	MDD (MLD)	MDD Peaking Factor
2016	1.16	3.02	2.60
2021	1.50	3.40	2.27
2026	1.48	3.27	2.25
2031	1.45	3.21	2.24
2041	1.40	3.10	2.21

2.2.2 Diurnal Demand Pattern

The SCADA records from 2017 were considered for the estimation of the diurnal consumption pattern in Mount Albert for three different periods: February as representative of the winter season, May as representative of transition period between winter and summer, and August as representative of the summer season. In addition, weekdays and weekends were assessed separately, and curves developed for each.

In general, the equations applied to determine the consumption based on the SCADA parameters are:

$$C = W_1 + W_2 + W_3 - T_{1-IN} - T_{2-IN} \quad \text{when pumping}$$

$$C = T_{1-OUT} + T_{2-OUT} \quad \text{when not pumping}$$

Where,

C = water consumption

W_1 = water pumped from Well 1

W_2 = water pumped from Well 2

W_3 = water pumped from Well 3

T_{1-IN} = inflow to North Elevated Tank

T_{1-OUT} = outflow from North Elevated Tank

T_{2-IN} = inflow to South Elevated Tank (zero, as not in service in 2017)

T_{2-OUT} = outflow from South Elevated Tank (zero, as not in service in 2017)

The weekday hourly demands for the three periods (February, May, and August 2017) were averaged to obtain a weekday diurnal curve for the system. Similarly, the weekend hourly demands for the three periods were averaged to obtain a weekend diurnal curve for the system. The calculated system diurnal consumption patterns for weekday and weekend are shown in Figure 2-2.

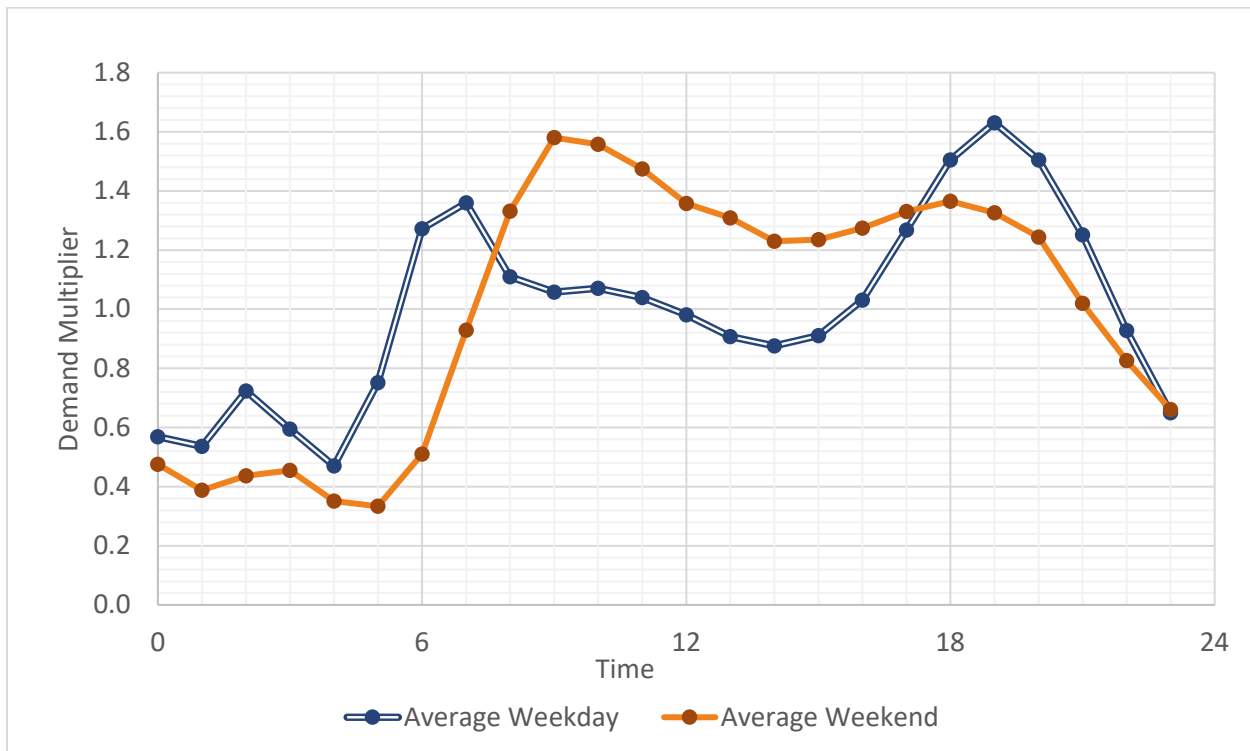

Figure 2-2 Diurnal Demand Patterns

2.2.3 Fire Flow Requirement

The York Region’s *Environmental Services Department Capital Planning and Delivery Branch Design Guidelines – Section 16 – Water Systems* (Region Design Guidelines) indicate that a commercial or industrial fire of 10,000 liters per minute (L/min) (166.7 liters per second [L/s]) for a duration of 2 hours should be used for the design of smaller pressure districts with smaller commercial, and medium or high-density residential areas (Section 16 – Water Systems, Subsection 16.4.7). The Mount Albert system would be considered a small pressure district and therefore the target of 10,000 L/min (167 L/s) for a duration of 2 hours would apply.

The East Gwillimbury Engineering Standards and Design Criteria indicate the following minimum fire flow requirements: Residential is 4,800 L/min (80 L/s), and Employment is 12,000 L/min (200 L/s) for a duration of 2.5 hours.

To confirm targets for Mount Albert, the Fire Underwriters Survey (FUS) method was used to estimate fire flow requirements. Generally, the method consists of estimating the required fire flow as a function of the building area and a coefficient related to the type of construction (ranges from combustible to fire-resistive construction). This base fire flow is then successively adjusted based on variables such as building contents, the presence of sprinklers, and the building’s degree of exposure (i.e. the degree of separation from other nearby constructions that might increase the fire flow requirement). On a case-by-case basis, each of these variables could increase or decrease the base value initially estimated. Using the FUS, fire flow targets for low density residential, medium density residential, and Institutional/Commercial/Industrial were developed. The calculations are summarized in Table 2-4. The calculations for each target are provided in Appendix A.

Table 2-4. Fire Flow Targets

Fire Flow Target Category	Fire Flow Calculation					
	Area (square metres)	Construction Coefficient	Occupancy Hazard	Sprinkler Protection	Exposure Surcharges	Total Fire Flow Requirement
Residential – Low Density (> 10 metres) ¹	-	1.5	-	-	-	50 L/s
Residential – Low Density (3 to 10 metres) ¹	-	1.5	-	-	-	67 L/s
Residential – Low Density (< 3 metres) ²	372	1.5	-20%	0%	+60%	133 L/s
Residential – Medium Density ³	581	1.5	-20%	0%	+60%	167 L/s
Institutional, Commercial, Industrial ⁴	1,042	1.0	0%	0%	+60%	183 L/s
Institutional (Mount Albert School) ⁵	6,033	0.8	-20%	0%	+30%	250 L/s

Notes:

1. Using the short method under Note J, *Fire Underwriters Survey Water Supply for Public Fire Protection, 1999* for the building separation distances indicated. Separation distance between adjacent buildings indicated in brackets.
2. Assuming a 4,000 sq.ft. house with 3 m or less separation distance on each side from adjacent buildings.
3. Assuming a 5-unit townhouse with an average of 1,250 sq.ft. per townhouse, and no fire walls separating the units.
4. Based on the Mount Albert Community Centre.
5. Based on the Mount Albert School. Assuming there is no sprinkler protection.

Based on the noted York Region, East Gwillimbury, and FUS targets, and discussions with York Region staff, the following fire flow targets are established for this study:

- York Region Owned Infrastructure (Well Facilities, Elevated Tanks, Transmission Mains):
 - 10,000 L/min (168 L/s) for 2 hours
- East Gwillimbury Owned Infrastructure (Watermains):
 - FUS targets indicated in Table 2-4

3. Hydraulic Model Calibration and Validation

3.1 Field Testing and System Monitoring

The *C-Factor and Fire Flow Testing Plan, May 2019 (Testing Plan)* was developed to outline the field testing and data collection work required to complete the WDS hydraulic model calibration and validation (see Appendix B for the full plan). The plan outlined the proposed C-Factor tests, fire flow tests, and pressure and flow monitoring.

3.1.1 C-Factor Testing

The Hazen-Williams formula is most commonly used to estimate the flow through a pipe given a pipe's physical properties. The Hazen-Williams pipe roughness coefficient or C-Factor is used as an estimate of a given pipe's resistance to flow. Smoother pipes, which have less resistance, will have higher C-Factors. In general, larger diameters, and smoother materials (plastics) tend to have higher C-Factors. However, C-Factor also accounts for bends, and other restrictions such as partially closed valves, so may be lower than what is expected for the pipe friction alone.

The WDS was examined to identify pipe roughness groups based on material, diameter, and physical location of pipes, and the C-Factor test locations were based on these identified pipe groups. Each C-Factor test is done by first creating a dead-end pipe through closing of select valves. Then a fire hydrant at the dead-end is flowed, and the pressure drop between two other fire hydrants along the pipe segment is measured. This pressure drop is used to calculate the C-Factor for this pipe segment.

Initially ten C-Factor test locations were proposed (three Polyvinyl Chloride (PVC), and seven Ductile Iron (DI) tests) (refer to the Testing Plan for additional details). On the day of the testing, it was found that after the completion of each C-Factor test, a longer period of flushing was required to clear water discoloration before the hydrant could be returned to service. The impact of system maintenance will be discussed further in subsequent reports. With the time available, for only 8 of the 10 planned tests could be completed and the decision was made to prioritize the DI locations as it was not expected that the C-Factors for PVC pipes would vary greatly between locations. Therefore, only one of the three PVC tests was completed. The C-Factors obtained from the testing are summarized in Table 3-1.

Table 3-1. C-Factor Test Results

Test #	Material	Size (millimetres)	Year of Installation	Field Test Calculated C-Factor	Average Pipe Group C-Factor	Reference C-Factor ¹
2	PVC	150	2010	145.8	145.8	100
3	PVC	150	1995	Note 2		
5	PVC	200	2014	Note 2	N/A	110
1	DI	150	1977	130.3	126.5	100
10	DI	150	2006	122.7		
7	DI	200	1977	122.4	116.2	110
9	DI	200	1977	110.0		
4	DI	250	1976	135.6	127.3	115
6	DI	250	1980	119.1		

Test #	Material	Size (millimetres)	Year of Installation	Field Test Calculated C-Factor	Average Pipe Group C-Factor	Reference C-Factor ¹
8	DI	350	1977	120.2	120.2	120

Notes:

1. Suggested values based on pipe diameter, from *Ontario Ministry of Environment, Conservation, and Parks Design Guidelines for Drinking-Water Systems, 2008*.
2. Due to time constraints, and time required for flushing, these tests were not able to be completed.

The results generally follow the expected trend of higher C-Factors for smoother pipes (plastic), and for the larger diameters of DI pipes. However, there are some exceptions that did not follow the expected trend (e.g. results for Ductile Iron classes 200- and 350-millimetre are lower than classes 150- and 250-millimetre). Lower than expected C-Factors could be due to unknown restrictions within the test pipe, such as partially closed valves, deposition (which reduces the effective cross-sectional area), and whether the pipe is lined or un-lined.

Based on the values obtained from the C-Factor tests in Table 3-1, including interpolated and extrapolated values for the missing pipe groups, the initial C-Factors were established in the hydraulic model. These values were then adjusted in the Micro Calibration step discussed in Section 3.2.3.

3.1.2 Fire Flow Testing

To improve the quality of the hydraulic calibration of the WDS model requires that the system be examined under high flow conditions. Therefore, several fire flow tests were completed to simulate high flow conditions in the WDS. During these fire flow tests, the system pressures and flows were monitored to see how the system reacted to the high flows.

The existing WDS configuration was examined to identify the locations for the ten fire flow tests (refer to the Testing Plan for additional details). The locations were selected to provide coverage of the whole system. The data from these tests were entered in to the InfoWater Calibrator Tool during the Micro Calibration step discussed in Section 3.2.3.

3.1.3 System Pressure and Flow Monitoring

The purpose of the system pressure and flow monitoring was to capture the conditions in the WDS for the week that included the fire flow tests. The data collected (from SCADA, and from hydrant pressure monitors) during the fire flow test days was used for the hydraulic calibration, and the data collected during the non-test days was used for the hydraulic validation.

The flow, pressure, and water level data recorded in the SCADA system for the Ninth Line Elevated Tank, and Wells 1, 2, and 3 were used to identify facility conditions. To determine pressures within the distribution network, eight fire hydrant pressure monitors were proposed. These were strategically located to obtain key pressure data near the fire flow tests, and along major flow paths. Due to a logger failure at one location (109 King Street), pressure data was only recorded at seven of the eight locations. After examination and testing (using the hydraulic model) of the available data, it was determined that the remaining data was sufficient to meet the calibration criteria.

3.2 Hydraulic Calibration and Validation

3.2.1 Overview

The purpose of hydraulic calibration is to adjust model parameters to minimize discrepancies between the modeled and observed flows and pressures. The purpose of hydraulic validation is to check the adjustments made in the calibration stage. The model calibration and validation are an iterative process whereby adjustments are made, and then checked in the validation until the difference between the observed and modelled values is within the calibration criteria established. For this project the following criteria were used:

- Pressures: ± 20.6 kPa (3 psi) for 90% of readings
- Flows and Tower Levels: $\pm 10\%$ for 100% of readings

The first step in the hydraulic calibration process is macro calibration. This involves a review of field data to identify any sources of error, setting the model scenario initial conditions (e.g. water demands, pump scheduling, tank level), inputting the selected C-Factors from the testing discussed in Section 3.1.1, and adding fire hydrant junctions and elevations for fire flow test hydrants and fire hydrant pressure monitors.

The second step in the hydraulic calibration is micro calibration. This involves inputting the fire flow testing, and pressure and flow monitoring data in to the InfoWater Calibrator Tool and running the tool to obtain adjusted pipe C-Factors. The tool is run iteratively, while adjusting different model boundary conditions to obtain the final calibrated C-Factors. The hydraulically calibrated model will then be used to calibrate the water quality (chlorine residual).

3.2.2 Hydraulic Macro Calibration

The accuracy of the input elevation data for the tank, well facilities, and test hydrant pressure instruments, as well as initial C-Factors in the model can heavily impact the final quality of the calibration results produced by the InfoWater Calibrator Tool. This can occur due to incorrect boundary condition settings such as pump status, valve status, or tank levels. An initial evaluation of the variances in the field data and the model data was completed to identify any underlying trends that did not align, and could lead to failure of the calibrator tool. Upon review, no major issues were identified.

As surveyed elevations for the fire hydrant pressure monitors were not available, a typical elevation of 0.25 m above the adjacent junction ground elevation was assumed for modelling purposes. Separate junctions and pipes were added to the model for each fire hydrant and lateral used in the calibration. Critical elevations for the tank and well facilities were based on as-built drawings

The SCADA data was reviewed to compare the model predicted and actual system pressures. Since 9 of the 10 fire flow tests occurred when the pumps were off, a minor loss of 50 was added to the Ninth Line Elevated Tank discharge to adjust the model predicted pressures to achieve better correction with the observed values.

3.2.3 Hydraulic Micro Calibration

After the macro calibration was complete, a more detailed, discrete evaluation was conducted on individual sets of fire hydrant test data using the InfoWater Calibrator Tool. The tool adjusts the pipe C-Factors within a range of reasonable values (based on the initial assumed value from C-factor test data) to achieve the optimal pressure results across the fire flow tests. The tool uses genetic algorithms to run many iterations, filtering on each round, to find the optimal solution that best fits the flow and pressure field data.

The SCADA data was reviewed for the fire flow testing days to determine the system demands during the testing period. Since the tests themselves are an additional demand on the system, the test times were excluded from the calculation of the average system test day demands. An adjustment factor was applied to the calibration scenario demands, to match the actual system demands over the test days.

For nine out of ten tests, the well pumps were off, and the tank was draining. For one of the tests, the well pumps were on, and the pump flows were simulated by entering a negative demand (input) at the pump discharge. This allowed the removal of a variable (pump) during the hydraulic calibration process.

The SCADA data was also reviewed to determine the initial tank level for each fire flow test. These were entered in to their own dataset in the model, and assigned to their corresponding fire flow test set within the Calibrator tool.

The initial C-Factors used in the base calibration scenario are shown in Table 3-2. These initial values were selected based on an assessment of the C-Factor test data. For PVC, only one test was completed, and therefore the value of 145.8 was assigned to all PVC pipes. For DI, the C-Factor test data for the 200- and 350-millimetre-diameter pipes showed lower C-Factors than the 150- and 250-millimetre-diameter pipes. Therefore, the 200 mm diameter pipe C-Factor was interpolated from the 150- and 250--millimetre-diameter pipes. Additionally, the 300- and 350-millimetre-diameter pipes were assumed to be have the same C-Factors as the 250-millimetre-diameter pipe. The C-Factor range was initially defined as +/- 10% of the initial values. However, for the DI pipes the tool was maxing out on the C-Factor range (based on the initial values), so the range was shifted up by a C-Factor of 10. Additionally, the maximum range values for the largest diameter groups (300, 350, and 400 millimetres) were all increased by a C-Factor of 10.

The InfoWater Calibrator Tool was run, and based on the results additional modifications were made to the above mentioned input parameters (e.g. tank minor loss, fire flow demands, system demands, and tank level) to achieve a better match between the observed and predicted pressures. Several iterations were completed with adjustments to the initial conditions, to achieve optimal results system-wide. The final calibrated C-Factors are summarized in Table 3-2. The calibrated C-Factors are generally within the range of expected values for the pipe material and diameter combinations. Pipe groups with lower than expected C-Factors (e.g. PVC 300/350 millimetres) could be due to several factors. One factor could be partially closed isolation valves in the WDS, causing additional headloss along a specific segment.

Table 3-2. Calibrated Pipe C-Factors

Group #	Material	Size (millimetres)	Initial C-Factors Prior to Calibration ¹	C-Factor Range Provided in Calibrator Tool	Final C-Factors After Calibration
1	PVC	150	145.8	131 to 160	135
2	PVC	200	145.8	131 to 160	155
3	PVC	250	145.8	131 to 160	154
4	PVC	300 / 350	145.8	131 to 170	131
5	PVC	400	145.8	131 to 170	170
6	DI	150	126.5	124 to 150	145
7	DI	200	126.9	124 to 150	135
8	DI	250	127.3	124 to 150	140
9	DI	300	127.3	124 to 160	160
10	DI	350	127.3	124 to 160	153
11	CPP ²	150 – 350	120.0	108 to 132	126
12	CPP ³	300	120.0	108 to 132	114

Notes:

1. Selected values for each model pipe group based on an assessment of the C-Factor field test data.
2. This group contains the CPP yard piping around the Well Facility 1&2.
3. This group contains the CPP yard piping around the Ninth Line Elevated Tank.

3.2.4 Hydraulic Validation

The hydraulic validation was completed to determine whether the calibration achieved the target level of accuracy (as defined in Section 3.2.1) for this project. This was an iterative process as the calibration parameters were adjusted, the Calibrator Tool re-run, and the validation scenario re-run with updated C-Factors. Once the target accuracy was achieved, the model was considered calibrated.

The pressure and flow criteria are shown graphically on the pressure and flow correlation plots in Figure 3-1 and Figure 3-2, respectively. The correlation plots show that the model meets the target calibration accuracy. The pressure and flow accuracy of the calibrated model are:

- Pressures: Average difference of 4.9 kPa (0.7 psi) for 100% of the pressure readings (target \pm 20.6 kPa (3 psi) for 90% of readings).
- Flows: Average difference of 0.8 % for 100% of the flow readings (target \pm 10% for 100% of readings).

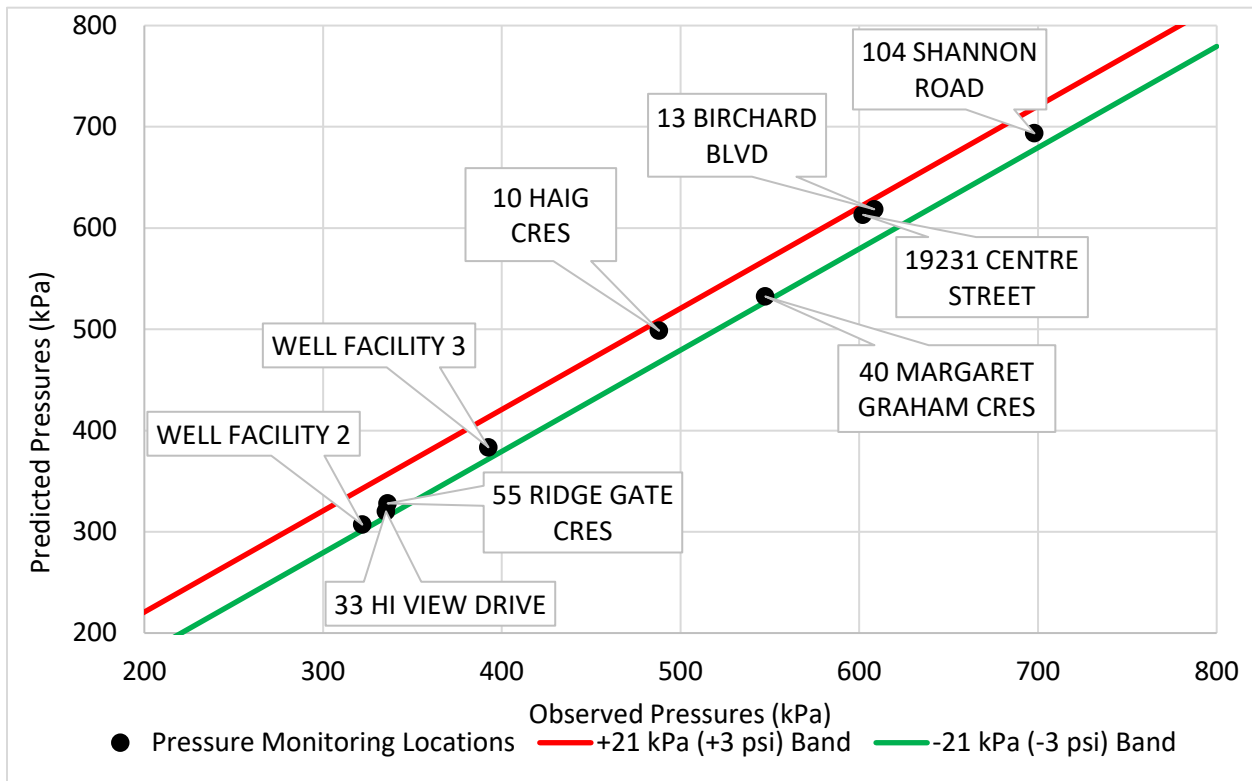

Figure 3-1 Hydraulic Validation Pressure Correlation Plot

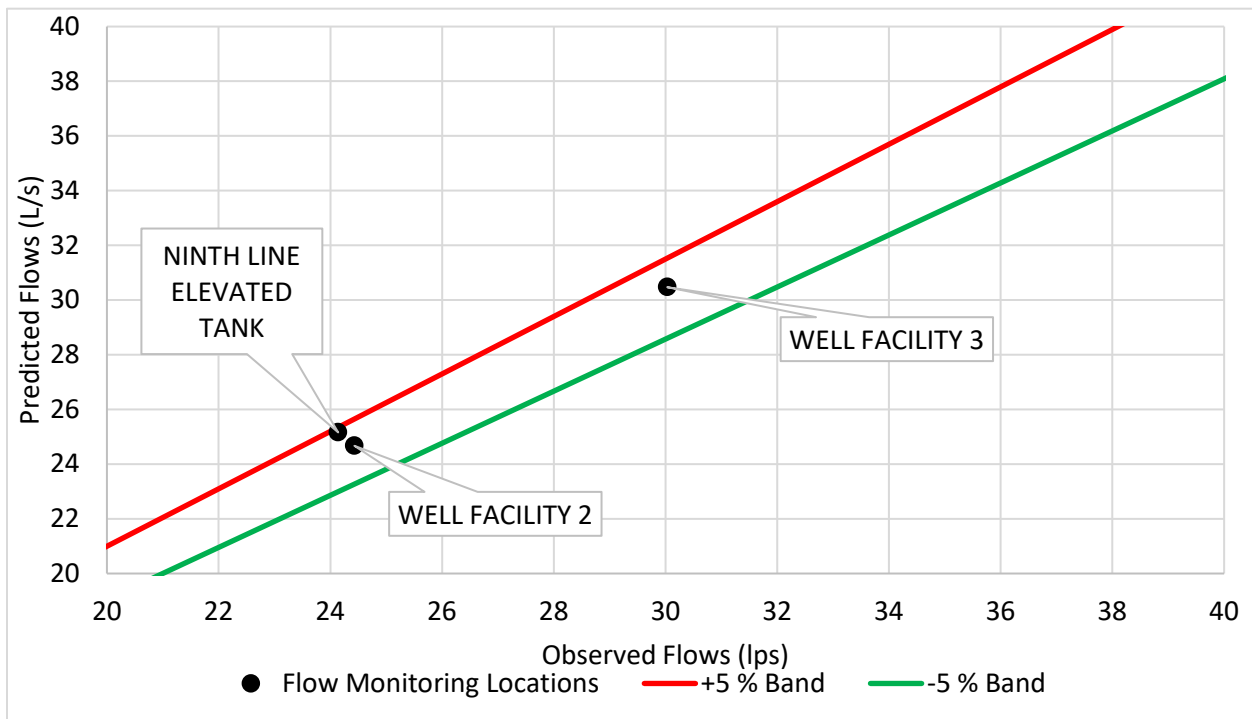

Figure 3-2 Hydraulic Validation Flow Correlation Plot

4. Water Quality Model Calibration and Validation

4.1 Water Quality Sampling

The *Water Quality Sampling Plan, July 26, 2019 (Sampling Plan)* was developed to outline the water sample collection work required to complete the WDS hydraulic model water quality calibration and validation (see Appendix C for the full plan). The plan outlined the proposed locations and frequency for water sample collection. Sampling was completed to determine the chlorine bulk decay, to determine the concentration of chlorine in the WDS over time, and to determine the concentration of iron and manganese in the WDS over time (Appendix F).

4.1.1 Chlorine Bulk Decay Sampling

For the bulk chlorine decay analysis, eight samples were collected at each of the well facilities. The samples were collected from a constantly flowing treated water sample port, located downstream of chlorination and silicate addition and the chlorine contact tanks at each facility. The free chlorine was measured at 0, 0.5, 1, 2, 4, 6, 24, 48, and 72 hours, with duplicate measurements performed at each time interval.

The average bulk decay coefficient over the 72-hour period was calculated for the water from wells 2 and 3 (the active facilities during the sampling period) using the following equation:

$$K_{ave} = \frac{\ln C_{l_{final}} - \ln C_{l_{initial}}}{T_{final} - T_{initial}}$$

where, K_{ave} is the average bulk decay coefficient, $C_{l_{final}}$ is the chlorine concentration after 72 hours, $C_{l_{initial}}$ is the chlorine concentration at 0 hours, T_{final} is 72 hours, and $T_{initial}$ is 0 hours.

The calculated bulk decay coefficients using the above equation are as follows:

- Well 2 Facility = - 0.0986 / day
- Well 3 Facility = - 0.0761 / day

Note that these decay coefficients represent the rate of bulk decay after the raw water has been chlorinated and has gone through a chlorine contact tank.

4.1.2 Distribution System Chlorine Sampling

To complete the water quality calibration requires information about the chlorine concentration in the distribution system over time. Ten samples were collected at each of the eight sampling locations over a 24-hour sampling period. This sample collection was completed twice, July 17 to July 18, and August 1 to August 2, 2019.

The existing WDS configuration was examined to identify the locations for the eight sampling locations (refer to the Sampling Plan for additional details). The locations were selected to provide coverage of the distribution system to identify how the water quality changes with factors such as water demands, distance from wells, storage tanks, and distribution mains. The data from these tests were entered in to the InfoWater Water Quality Calibrator Tool during the Micro Calibration step discussed in Section 4.2.3.

4.1.3 Distribution System Iron and Manganese Sampling

Distribution system iron and manganese samples were also collected per the sampling plan in Appendix C. The results are currently being analyzed and will be formally reported on under separate cover.

4.2 Water Quality Calibration and Validation

4.2.1 Overview

The purpose of the water quality calibration is to adjust model parameters to minimize discrepancies between the modeled and observed chlorine residual concentrations. The purpose of the water quality validation is to check the adjustments made in the calibration. This is an iterative process whereby adjustments are made, and then checked in the validation until the difference between the observed and modelled values is within the calibration criteria established. For this project the following criteria were used:

- SCADA: ± 0.1 milligrams per liter (mg/L) for 90% of readings
- Grab Samples: ± 0.2 mg/L for 85% of readings

The first step in the water quality calibration process is macro calibration. This involves a review of field data to identify any sources of error, setting the model scenario initial and EPS hydraulic conditions (e.g. patterns for water demands, pump scheduling, and tank level), and setting the initial and EPS quality conditions (e.g. well chlorine residual concentration patterns, bulk decay coefficients for the model pipes, and initial concentrations at the model junctions).

The second step in the water quality calibration is micro calibration. This involves inputting the chlorine residual sample data in to the InfoWater Water Quality Calibrator Tool and running the tool to obtain adjusted pipe wall decay coefficients.

4.2.2 Water Quality Macro Calibration

An initial evaluation of the variances in the field data and the model data was completed to identify any underlying trends of data that did not align and could lead to failure of the calibrator tool. This can occur due to incorrect boundary condition settings such as pump status, valve status, or tank levels. Upon review, no major issues were identified.

The SCADA data was reviewed for the sampling days to create the system demand pattern during the sample period. The demand pattern was applied to the model water quality calibration scenario demands, to match the actual system demands over the 24 hours.

The SCADA data was also reviewed to identify flows for the well pumps, and the Ninth Line Elevated Tank, and were then compared to the hydraulically calibrated model predicted flows, and they were found to match. The model control patterns were generated to match the on and off setpoints observed in the SCADA data over the time period.

Finally, the SCADA data was examined to identify the initial tank level for the calibration time period, and this was entered into the dataset.

With these hydraulic conditions defined in the model, the micro calibration step could be completed.

4.2.3 Water Quality Micro Calibration

With the hydraulic conditions established in the model during the macro calibration, a more detailed, discrete evaluation was conducted on individual sets of calibration data using the InfoWater Water Quality Calibrator Tool. The tool adjusts the pipe wall decay coefficients within a bounded range of reasonable values (based on values from other projects for the Region and other municipalities) to achieve optimum chlorine residual results system-wide. The tool uses genetic algorithms to run many iterations, filtering on each round, to find the optimal solution.

The SCADA data was reviewed to determine the chlorine residual concentrations at each well facility. Chlorine residual concentration patterns for each well facility were developed and entered in to the model.

The bulk decay and initial wall decay coefficients need to be defined at each pipe, and the initial chlorine concentrations need to be defined at each junction. The bulk decay coefficients at each pipe were determined through examining the amount of water in each pipe that was from Well Facility 1&2 and Well Facility 3. A source trace analysis was completed, which provides the percent of water at each junction or pipe in the system that came from any selected source. Using the source trace percent, and the bulk decay coefficients for each well shown in Section 4.1.1, the blended bulk decay coefficient at each pipe was determined. Several iterations of the source trace analysis were completed using the final value from each iteration as the initial value of the subsequent one. This was done until the values stabilized.

An initial wall decay coefficient of -0.001 was assigned to all pipes in the network for setup of the initial conditions. These wall decay coefficients were subsequently updated using the InfoWater Quality Calibrator tool.

To assign the initial chlorine residual concentrations throughout the WDS, Theisen polygons were generated using the grab sample locations. The initial value at each sampling location was assigned to all the junctions within its Theisen polygon.

The same pipe groups were used for the water quality calibration, as were defined for the hydraulic calibration. The final calibrated wall decay coefficients are summarized in Table 4-1.

Table 4-1. Calibrated Pipe Wall Decay Coefficients

Group #	Material	Size (millimetres)	Wall Decay Coefficient Range Provided in WQ Calibrator Tool	Final Wall Decay Coefficients After Calibration
1	PVC	150	-0.0001 to -0.1	-0.00609
2	PVC	200	-0.0001 to -0.1	-0.09201
3	PVC	250	-0.0001 to -0.1	-0.00410
4	PVC	300 / 350	-0.0001 to -0.1	-0.00809
5	PVC	400	-0.0001 to -0.1	-0.10000
6	DI	150	-0.0001 to -0.1	-0.10000
7	DI	200	-0.0001 to -0.1	-0.08901
8	DI	250	-0.0001 to -0.1	-0.01109
9	DI	300	-0.0001 to -0.1	-0.05105

Group #	Material	Size (millimetres)	Wall Decay Coefficient Range Provided in WQ Calibrator Tool	Final Wall Decay Coefficients After Calibration
10	DI	350	-0.0001 to -0.1	-0.06104
11	CPP ¹	300	-0.0001 to -0.1	-0.01209
12	CPP ²	250 – 350	-0.0001 to -0.1	-0.00609

Notes:

1. This group contains the CPP yard piping around the Well Facility 1&2.
2. This group contains the CPP yard piping around the Ninth Line Elevated Tank.

4.2.4 Water Quality Validation

The water quality validation was completed to determine whether the calibration achieved the target level of accuracy (as defined in Section 4.2.1) for this project. This was an iterative process as the calibration parameters were adjusted, and then the validation scenario re-run with updated wall decay coefficients. Once the target accuracy was achieved, the model was considered calibrated.

The chlorine residual concentration validation plot for the Ninth Line Elevated Tank is shown graphically in Figure 4-1. The validation plots for the eight sample locations in the WDS are shown in Appendix D. The validation plot shows that the model meets the target calibration accuracy. The SCADA and grab sample accuracy of the calibrated model are:

- SCADA: ± 0.1 mg/L for 92% of readings (target ± 0.1 mg/L for 90% of readings).
- Grab Samples: ± 0.2 mg/L for 91% of readings (target ± 0.2 mg/L for 85% of readings).

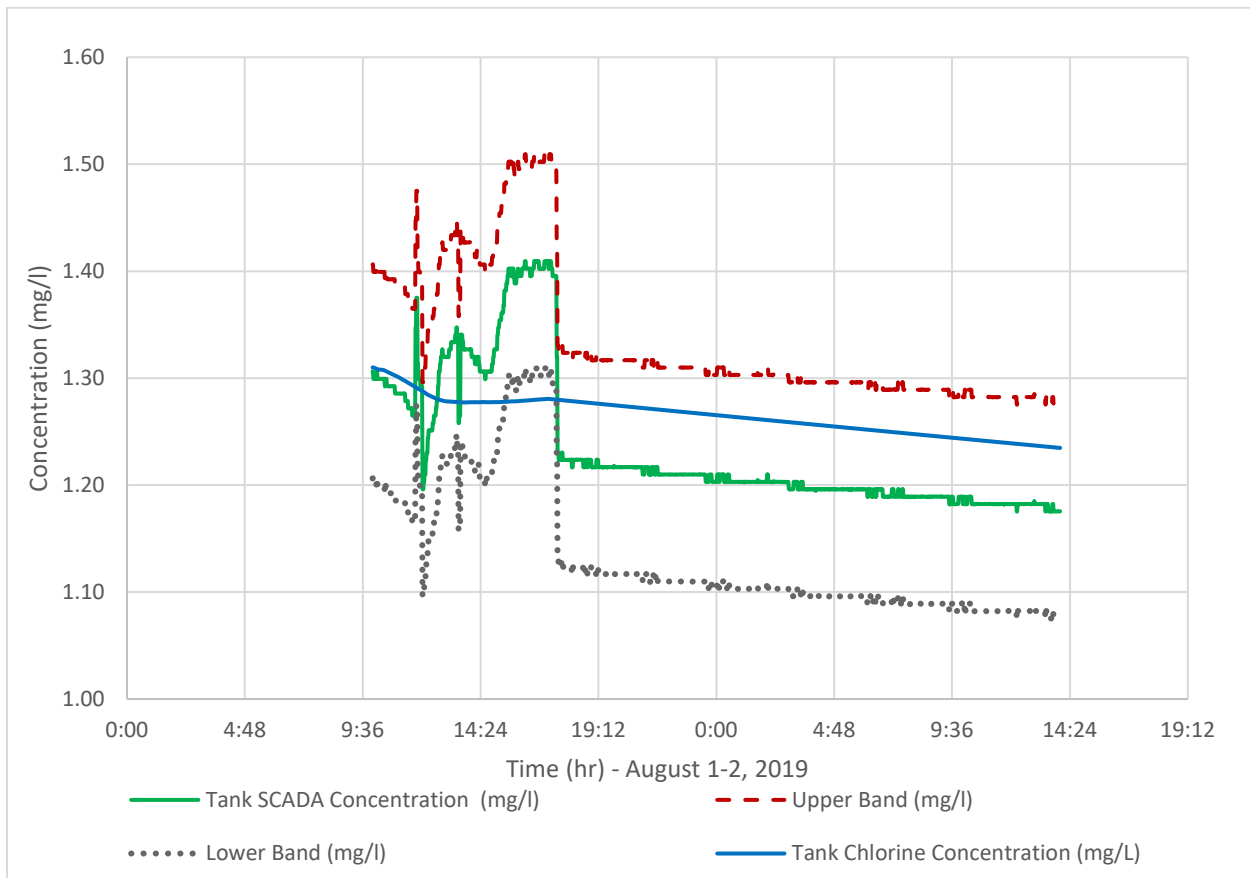

Figure 4-1 Ninth Line Elevated Tank Water Quality Validation Plot

5. Baseline Conditions Model Results

With both the hydraulic calibration / validation, and the water quality calibration / validation complete, the existing model scenario can be used to analyze the baseline conditions in the system. The minimum pressures under maximum hour demands, maximum pressures under minimum hour demand, available fire flow under maximum day demands, water age under average day demands, and chlorine residuals under average day demands were all examined. The model results for each of these parameters can be found in Appendix E. A summary of the results is provided in Table 5-1.

Table 5-1. Summary of WDS Baseline Conditions Model Results

Parameter	Demand Scenario and Simulation Type	Range of Values	Units
Pressure – Maximum	Average Day EPS ¹	328 – 742 (48 – 108)	kPa (psi)
Pressure – Minimum	Maximum Day EPS ²	242 – 657 (35 – 95)	kPa (psi)
Velocity – Maximum	Maximum Day EPS ²	0.01 – 0.91	m/s
Available Fire Flow	Maximum Day SS ³	69 – 197	L/s

Parameter	Demand Scenario and Simulation Type	Range of Values	Units
Water Age – Average	Average Day EPS	10 – 146	hours
Water Age – Maximum	Average Day EPS	29 – 222	hours
Chlorine Residuals – Minimum	Average Day EPS	0.45 – 1.45	mg/L
Chlorine Residuals – Average	Average Day EPS	0.67 – 1.56	mg/L

Notes:

Definitions: EPS – Extended Period Simulation, SS – Steady State

1. Maximum pressure occurs at the minimum hour demand on the diurnal curve. The weekend diurnal demand pattern was used for this analysis, since it has the lowest minimum hour multiplier, and would therefore be the most conservative.
2. Minimum pressure occurs at the maximum hour demand on the maximum day EPS scenario with diurnal demand curve. The weekday diurnal demand pattern was used for this analysis, since it has the highest maximum hour multiplier, and would therefore be the most conservative.
3. This scenario is a steady state simulation, and therefore has no diurnal demand pattern applied.

6. Analysis of Model Results and Opportunities for Performance Enhancement and Optimization

In the sections below the baseline conditions model results (summarized in Section 5, and full results in Appendix E) are analyzed, and opportunities for performance enhancement and optimization are identified to be further examined in the System Capacity Optimization Study:

- **Water Supply and Storage:**

The water storage and pumping requirements were calculated for the Mount Albert WDS and are presented in Appendix E. The 2016 water storage requirement was calculated to be 2,443 m³, and 2,736 m³ is estimated to be functionally available. Since the storage requirement is met, the pumping requirement is to meet MDD. Therefore, the 2016 pumping requirement is 3,016 m³/d, and the available pumping capacity is estimated to be 4,673 m³/d (based on recorded SCADA flows for Well Facilities 2 and 3). Therefore, the pumping requirement is met.

- **Pressure – Maximum:**

Areas northwest of Centre St. and Mt. Albert Rd. have the highest pressures, with many areas predicted to exceed the maximum pressure requirement of 689 kPa (100 psi) during the minimum hour demand. Options such as creation of new pressure zones, or individual pressure reducing valves in buildings could be examined to address these high pressures.

- **Pressure – Minimum:**

The areas around the intersection of Mount Albert Rd. and Centre St. do not meet the minimum pressures requirement of 276 kPa (40 psi) for the maximum hour demands. Other high elevation areas to the northeast and to the southwest of that intersection also fail to meet the minimum pressure requirement (minimum 243.1 kPa). Options such as creation of new pressure zones could be examined to address these low pressures.

- **Velocity:**

The maximum velocity in the WDS during the maximum hour demand conditions is 0.91 m/s. This is below the maximum velocity target of 2 m/s during normal demand conditions (i.e. not during fire flow conditions).

- **Fire Flow:**

The available fire flows in the system are determined by taking the maximum amount of water from each node in the model while simultaneously maintaining a residual pressure of 138 kPa (20 psi) at all points in the system, and not exceeding a velocity of 5 m/s in any watermain in the system.

Using the FUS targets defined in Table 2-4, most areas in the WDS meet their fire flow target. It was calculated that approximately 73% of the junctions meet their fire flow target (i.e. available fire flow is greater or equal to the target). The areas that failed to meet the fire flow target are typically located at dead ends, and some are for higher density townhouses requiring a higher fire flow target. Strategies to improve fire flows could be looping dead ends, and addition of fire pumps. Future developments should confirm that sufficient fire flows are available for the proposed building types (e.g. townhouses vs. single family houses).

- **Water Age:**

The maximum and average water ages during the 25-day (600 hour) simulation under ADD and MDD were examined. As expected, water ages near the Ninth Line Elevated Tank are predicted to be the highest and decrease with proximity to the well facilities. The ADD water age in the Ninth Line Elevated Tank stabilizes at an average of about 113 hours (4.7 days), with a maximum of 129 hours (5.4 days). The MDD water age in the tank stabilizes at an average of about 60 hours (2.5 days), with a maximum of 66 hours (2.8 days). Areas closer to the well facilities receive more fresh water than do areas closer to the elevated tank, so their average water ages are lower. Additionally, average water ages at dead-end pipes are higher than within looped areas, as dead-ends have lower water demands. It is expected that auto-flushers in the system would improve the water age at the dead ends where they are located.

Two factors are thought to contribute to the water age in the system, water demands and diameter of watermains, and the layout of the distribution system. The Mount Albert WDS and associated water demands are small, however, the diameter of watermains is governed by fire flow requirements. This means that there is a large volume of water in the watermains and tank, compared to the volume of water consumed, resulting in ageing.

The layout of the system (with the well facilities and elevated tank located on opposite sides), generally results in ageing of the water in the tank. When the pumps turn on, fresh water flows through the system and pushes the old water in the system into the tank. This water then comes back out of the tank and some of it is consumed. However, some of it is not consumed and gets pushed back into the tank when the pumps turn back on, resulting in ageing.

- **Chlorine Residual:**

The chlorine residual concentrations were examined under the ADD scenario and are predicted to be acceptable in all areas. The minimum chlorine concentration predicted in the system is 0.45 mg/L which is above the minimum regulatory requirement of 0.05 mg/L and the desired minimum of 0.40 mg/L for free chlorine systems. A pocket of low chlorine residual was observed around the Shannon Rd. area. The calibrated wall decay coefficients in Table 4-1 indicate that there is higher decay in the DI pipes, than in the PVC pipes. The flows through the Shannon Rd. area are small, and so the water stays in the DI pipes longer, and decays with the pipe walls. It is expected that the auto-flushers around the DI pipe area would improve the minimum chlorine residuals in this area.

7. List of Appendices

The following appendices are included with this TM:

- A. Fire Flow Target Calculations
- B. C-Factor and Fire Flow Testing Plan, May 2019
- C. Water Quality Sampling Plan, July 26, 2019
- D. Water Quality Validation Plots
- E. Hydraulic Model Results – Baseline Conditions
- F. Mount Albert Distribution System Iron and Manganese Sampling Results

Appendix A

Fire Flow Target Calculations

Residential - Low Density

Building: Large Single-Family House, < 3 m separation

Step 1 Size and Type of Construction

Area	ft2	
Area	371.61 m2	(estimated 4,000 sq.ft)
Coefficient	1.5	
Flow	6000.0 L/min	100.0 L/s

Step 2 Occupancy Hazard Reduction or Surcharge

Value	-20%
Flow	4800 L/min

Step 3 Sprinkler Protection Reduction

Value	0%
Reduction	0 L/min

Step 4 Exposure Surcharges

Exposure Distances			
North	>30	m	5%
East	2.5	m	25%
South	>30	m	5%
West	2.5	m	25%
Total	-	-	60%
Surcharge	2880.0	L/min	

Step 5 Fire Flow

Total	7,680	L/min	128.0 L/s
Round	8,000	L/min	133.3 L/s

Residential - Medium Density

Building: 5-Unit Townhome - Middle Unit - With No Firewalls

Step 1 Size and Type of Construction

Area	ft2	
Area	580.64 m2	(Estimated 1,250 sq.ft x 5 units)
Coefficient	1.5	
Flow	8000.0 L/min	133.3 L/s

Step 2 Occupancy Hazard Reduction or Surcharge

Value	-20%
Flow	6400 L/min

Step 3 Sprinkler Protection Reduction

Value	0%
Reduction	0 L/min

Step 4 Exposure Surcharges

Exposure Distances			
North	>30	m	5%
East	0	m	25%
South	>30	m	5%
West	0	m	25%
Total	-	-	60%

Surcharge 3840.0 L/min

Step 5 Fire Flow

Total	10,240 L/min	170.7 L/s
Round	10,000 L/min	166.7 L/s

Commercial, and Institutional

Building: Mt. Albert Community Centre

Step 1 Size and Type of Construction

Area	ft2	
Area	1042.00 m2	(6.1m x 13.4m x 2 storeys x 3 units)
Coefficient	1	
Flow	7000.0 L/min	116.7 L/s

Step 2 Occupancy Hazard Reduction or Surcharge

Value	0%
Flow	7000 L/min

Step 3 Sprinkler Protection Reduction

Value	0%
Reduction	0 L/min

Step 4 Exposure Surcharges

Exposure Distances			
North	>30	m	5%
East	2.5	m	25%
South	>30	m	5%
West	2.5	m	25%
Total	-	-	60%

Surcharge 4200.0 L/min

Step 5 Fire Flow

Total	11,200 L/min	186.7 L/s
Round	11,000 L/min	183.3 L/s

Commercial, and Institutional

Building: Mt. Albert Public School

Step 1 Size and Type of Construction

Area	ft2	
Area	6033.00 m2	(Floor 1 + 2 = 4189 m2 + 1844 m2)
Coefficient	0.8	
Flow	14000.0 L/min	233.3 L/s

Step 2 Occupancy Hazard Reduction or Surcharge

Value	-20%
Flow	11200 L/min

Step 3 Sprinkler Protection Reduction

Value	0%
Reduction	0 L/min

Step 4 Exposure Surcharges

Exposure Distances			
North	>30	m	5%
East	>30	m	5%
South	>30	m	5%
West	20	m	15%
Total	-	-	30%

Surcharge 3360.0 L/min

Step 5 Fire Flow

Total	14,560 L/min	242.7 L/s
Round	15,000 L/min	250.0 L/s

Appendix B

C-Factor and Fire Flow Testing Plan, May 2019

245 Consumers Road, Suite 400
 Toronto, Ontario M2J 1R3
 Canada
 T +1.416.499.9000

www.jacobs.com

Subject	C Factor and Fire Flow Testing Plan	Project Name	Mount Albert Water Supply System Upgrades
Attention	Region of York, Town of East Gwillimbury	Project No.	CE731500
From	Allanna Yahoda / Mauricio Rojas		
Date	May 7, 2019		
Copies to			

To support the calibration of the Mount Albert water supply model conducted as part of the Mount Albert Water System Supply Upgrades Class Environmental Assessment, Jacobs, supported by Watermark, will coordinate and conduct C-Factor and Fire Flow Testing throughout the distribution system.

1. Fire Flow Testing

Jacobs has reviewed the system model and identified sample locations that will provide data representative of the system. The sampling locations were selected in such a way that a representative range of pipe diameters (i.e. from 150 mm to 300 mm) and pipe ages (i.e. from 1976 to 2014) are covered. In relation to pipe materials, there are mainly two pipe materials in the system: north of Vivian Creek is mostly PVC pipe and south of the creek is mostly ductile iron. Ten locations uniformly distributed along the system have been selected, four to the north of Vivian Creek and six to the south. The locations are shown in Figure 1 and the residual hydrant Asset IDs shown in Table 1. The flow hydrant is to be selected in the field on a case-by-case basis during the testing to avoid any flooding impacts on private property. The pressure drop during the Fire Flow Testing at the highest and lowest hydrant locations in the system is going to be captured through the Pressure Testing as explained in Section 3. Throughout the testing the system should be operated under normal operating conditions. Boundary conditions such as the north elevated tanks level during testing will be determined through the corresponding SCADA data, pump status as well will be through the SCADA data.

Table 1: Fire Flow Hydrants

Fire Flow Test Hydrant Label	Residual Hydrant Asset ID
FF No. 1	FH681
FF No. 2	FH65
FF No. 3	FH92
FF No. 4	FH68
FF No. 5	9999
FF No. 6	FH486
FF No. 7	FH129

FF No. 8	FH89
FF No. 9	FH60
FF No. 10	FH409

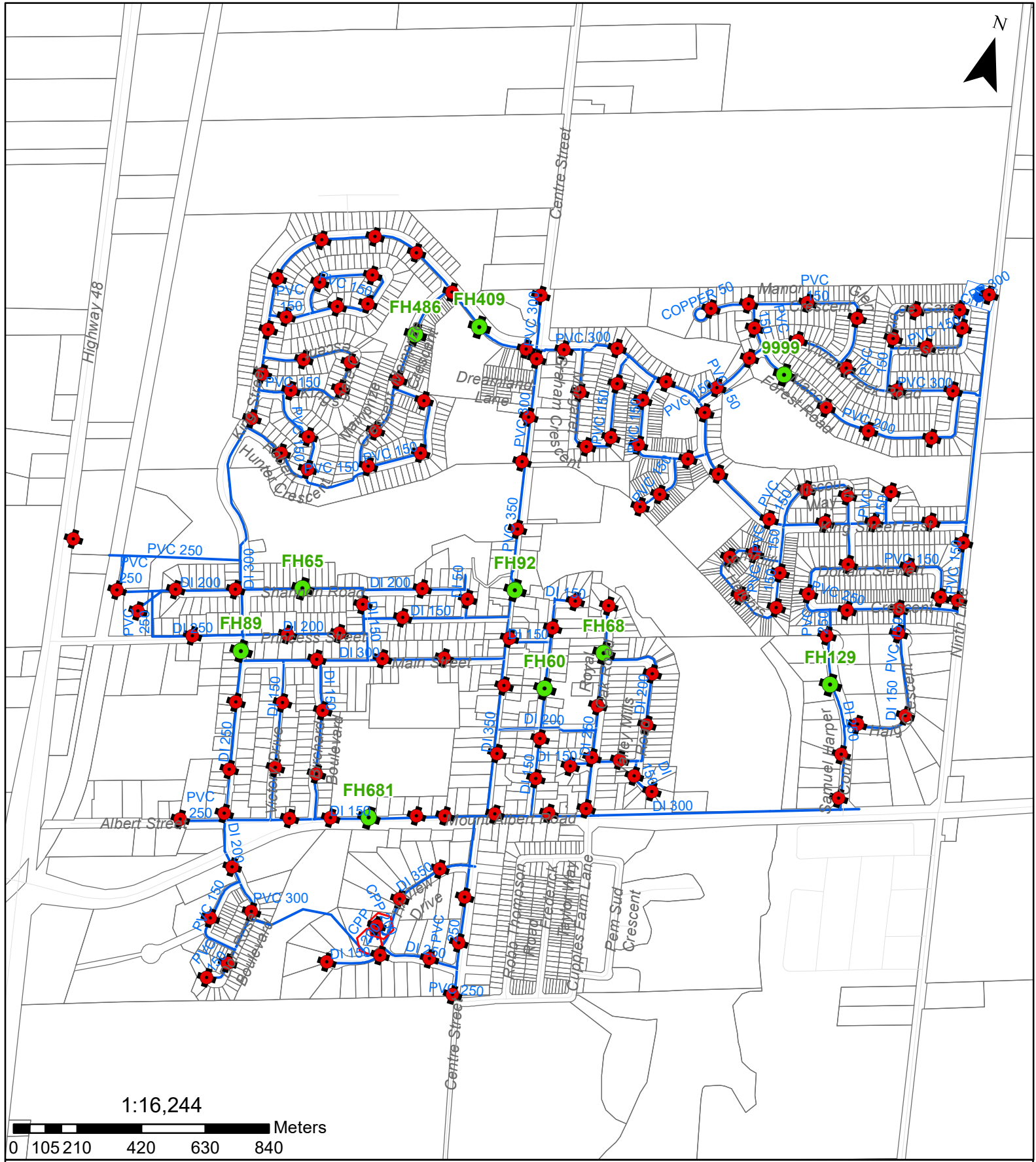

1:16,244

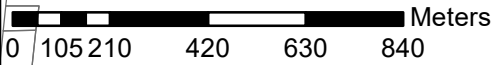

**Mount Albert Water Supply
System Upgrades
Schedule 'B' Class EA**

Figure 1- Fire Flow Test Locations

Note: Only the residual hydrants are shown. The corresponding flow hydrants are going to be defined in the field during the hydrant testing.

Legend

	Residual Pressure Hydrant		Production Well
	Hydrant		Elevated Tank

Watermark has provided the detailed description of the fire flow testing as follows:

Field service testing will be carried out by Watermark certified field technicians (FT) and overseen by the Field Supervisor. Watermark will provide a vehicle equipped to conform to Book 7 traffic control requirements for working in and around the roadway. Watermark technicians are fully trained and experienced in Book 7 and traffic management plans. Operations will be conducted between 07:30 to 16:00, Monday to Friday.

The field test procedure involves measuring the available flow under normal system conditions from fire hydrants and checking pressures on the water system, both static and residual.

A pressure logger will be installed onto the identified residual pressure test hydrant. This hydrant will be located close to the hydrant being tested; Watermark staff will monitor identified hydrants throughout the testing. Data loggers will be used during the Fire Flow testing, so that the recorded site data is documented electronically

The testing begins with one port fully open to achieve a minimum headloss of 10 psi as per AWWA M32 guidelines. A diffuser is installed to reduce the impact of the flow to local property and water is dechlorinated to reduce the impact on natural water bodies. The flow rate calculation is:

$$Q = 29.83cd^2\sqrt{p}$$

Where:

- Q is the flow in gpm
- c is the nozzle coefficient (shape of hydrant nozzle)
- d is the outlet diameter in inches
- p is the pitot reading in psi

Note: units will be converted to metric for reporting.

Digital field test records exported from the logging devices will be obtained and will be analyzed for the Fire Flow Test Results. The report will show:

- Detailed description of the procedures
- A summary of any operational/test issues found in the field
- Summary of the results in a tabular form based on the test numbers with all details (pipe size, length, accuracy, explanation about any unexpected values)
- Fire Flow test results with a calculated flow rate at 20 PSI for the residual hydrant.
- Total amount of water flowed during each test

Watermark will also sound all hydrants under test for leakage using an electromagnetic leak detection device and pump any non-draining hydrants after the flow test.

2. C-Factor Testing

The locations of the ten C-Factor tests and the details of valves to be closed during the testing are shown in Table 2 and in Figures 2 through 11. It is possible that in some tests 2 hydrants will need to be flowed depending on watermain size. It is advised that prior to the start of the field testing, East Gwillimbury operations staff locate the valves and confirms proper function of the valves.

Table 2: C-Factor Testing Details

C-factor Testing No.	Flow Hydrants	Pressure Hydrants	Valves to be closed
1	FH 60	FH 54, FH 91	MV 207, MV 236, MV 239
2	FH 747	FH 737, FH 743,	MV 753, MV 632
3	FH 486	FH 485, FH 497	MV 536, MV 546
4	FH 89, FH 64	FH 62, FH 93	MV 173, MV 170
5	N/A	N/A	Assumed at Manor Forest Rd and Vivian Creek Rd
6	FH 129, FH 130	FH 126, FH 127	MV 769, MV 315
7	FH 68	FH 31, FH 70	MV 228
8	FH 92, FH 2	FH 77, FH 78, FH 79	MV 837, MV 185, MV 203, MV 168, MV 236
9	FH 65	FH 80, FH 138	MV 194, MV 196
10	FH 683	FH 682, FH 681	MV 677

N/A: No Asset ID available on GIS provided

Watermark has provided the detailed description of the C-Factor Testing procedure as follows.

The Hazen-Williams Equation for flow in a closed conduit is:

$$V = 1.32 C_H R^{0.63} S^{0.54}$$

Where:

- V = flow velocity in fps
- R = hydraulic radius in ft (R = D/4 in circular pipes)
- S = slope of the total head or energy grade line
- C_H = Hazen-Williams coefficient

Note: units will be converted to metric for reporting.

The Hazen-Williams coefficient depicts the amount of head loss expected in the pipe. It is a function of pipe material, size, age and roughness. In order to be able to correctly estimated the Hazen-Williams "C" coefficient in an existing main; sufficient head loss must be achieved within the desired pipe section. This is accomplished by producing large flow rates, which in turn create high velocities and high friction or head losses in the pipe. Usually, a pressure differential of 25% between residual pressures at the two desired pressure monitoring points during the flow test is sufficient to create the desired head loss for "C" coefficient evaluation.

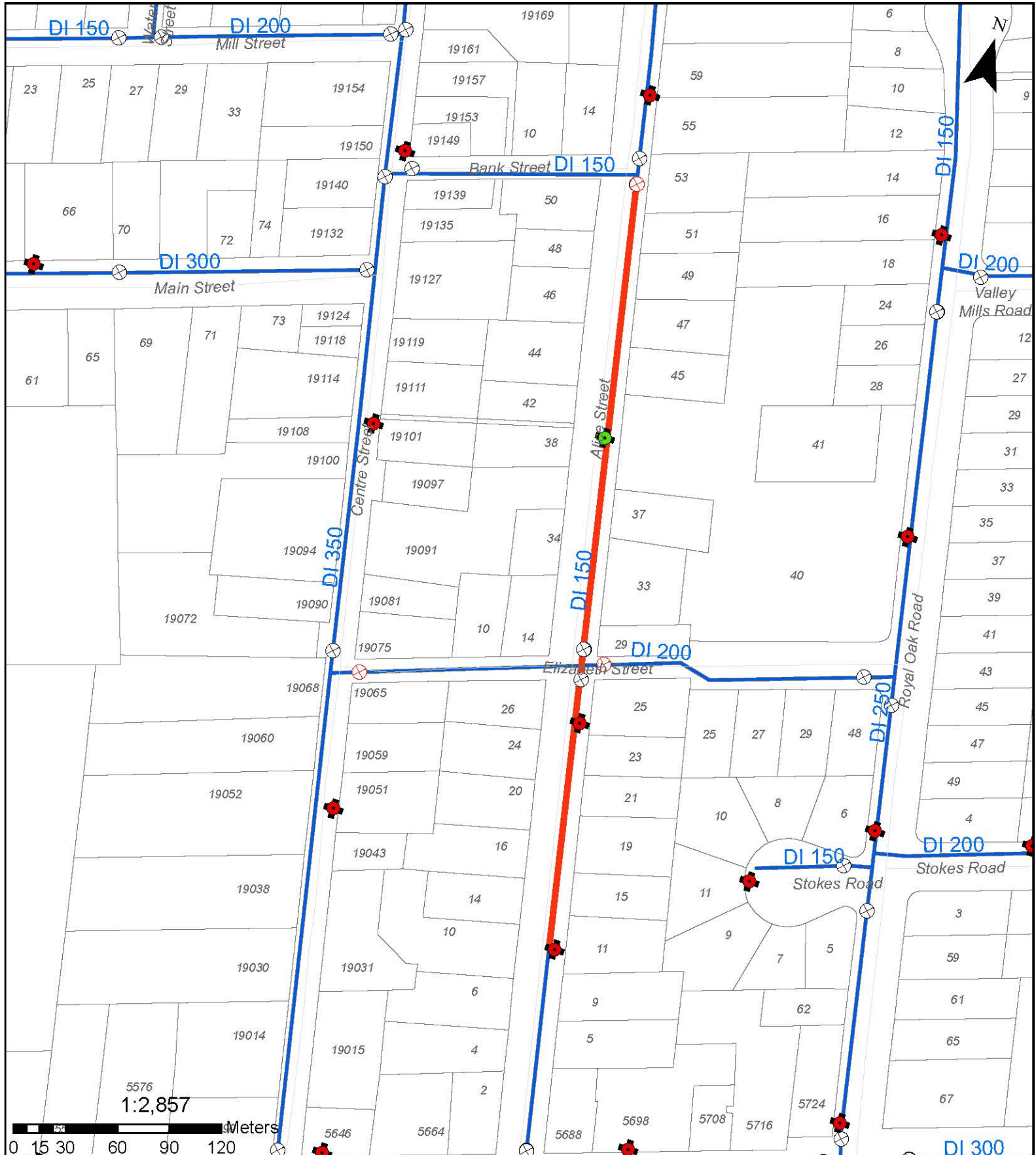



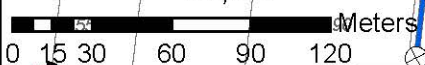

5576
1:2,857



**Mount Albert Water Supply
System Upgrades
Schedule 'B' Class EA**

**Figure 2- C-factor
Testing #1 DI 150 mm
Alice Street**

Legend







-  Flow Hydrant
-  Main Valve to be closed
-  Hydrant
-  Main Valve
-  Production Well
-  Elevated Tank
-  Test Pipes



**Mount Albert Water Supply
System Upgrades
Schedule 'B' Class EA**

**Figure 3- C-factor
Testing #2 PVC 150 mm
Donald Stewart Crescent**

Legend



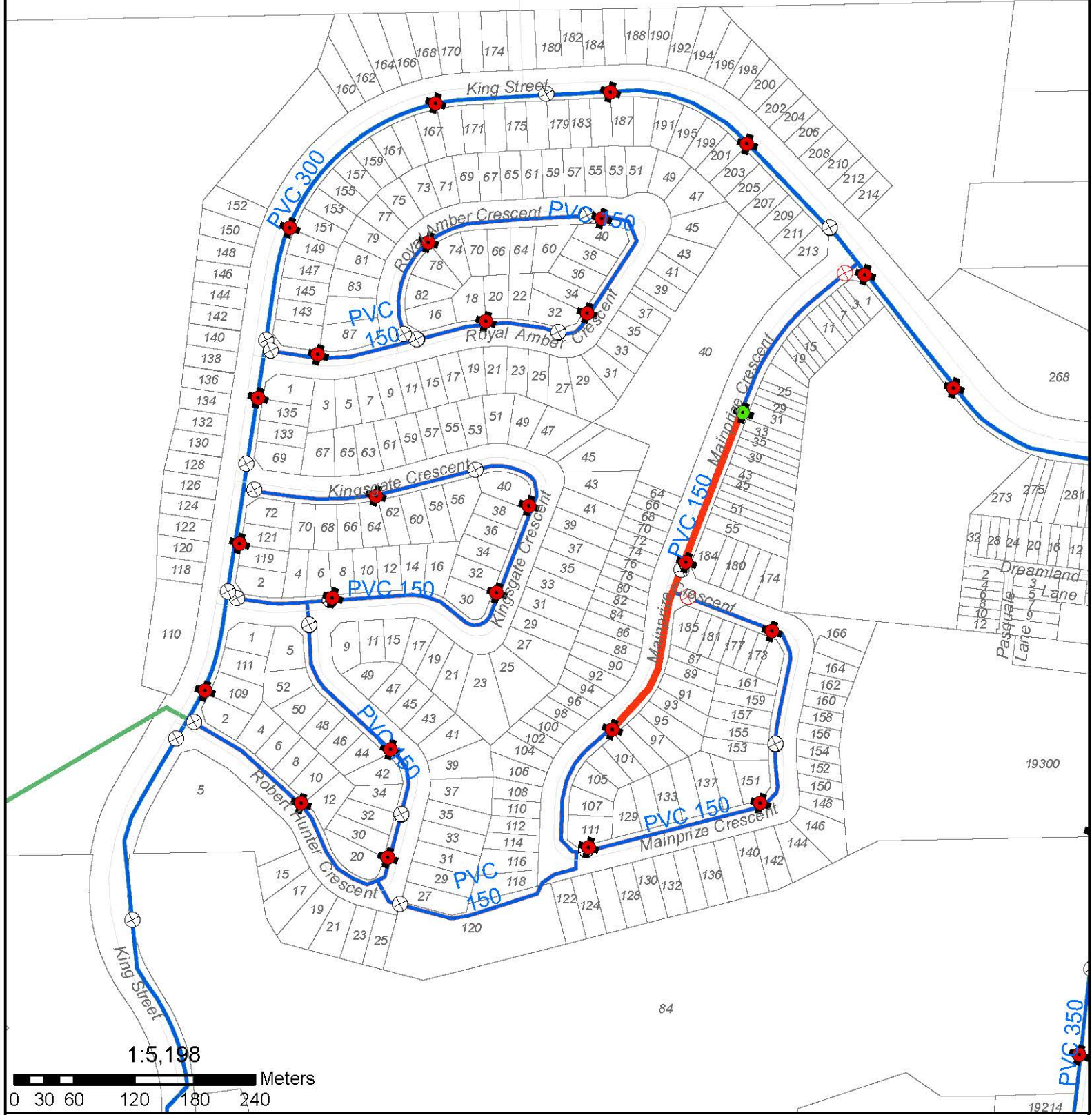



 Flow Hydrant	 Production Well
 Main Valve to be closed	 Elevated Tank
 Hydrant	 Test Pipes
 Main Valve	



**Mount Albert Water Supply
System Upgrades
Schedule 'B' Class EA**

**Figure 4 C-factor Testing #3
PVC 150 mm Mainprize
Crescent**

Legend







	Flow Hydrant		Production Well
	Hydrant		Elevated Tank
	Main Valve to be closed		Test Pipes
	Main Valve		



**Mount Albert Water Supply
System Upgrades
Schedule 'B' Class EA**

**Figure 5- C-factor
Testing #4 DI 250 mm
King Street**

Legend

-  Flow Hydrant
-  Hydrant
-  Main Valve to be closed
-  Main Valve
-  Production Well
-  Elevated Tank
-  Test Pipes

N

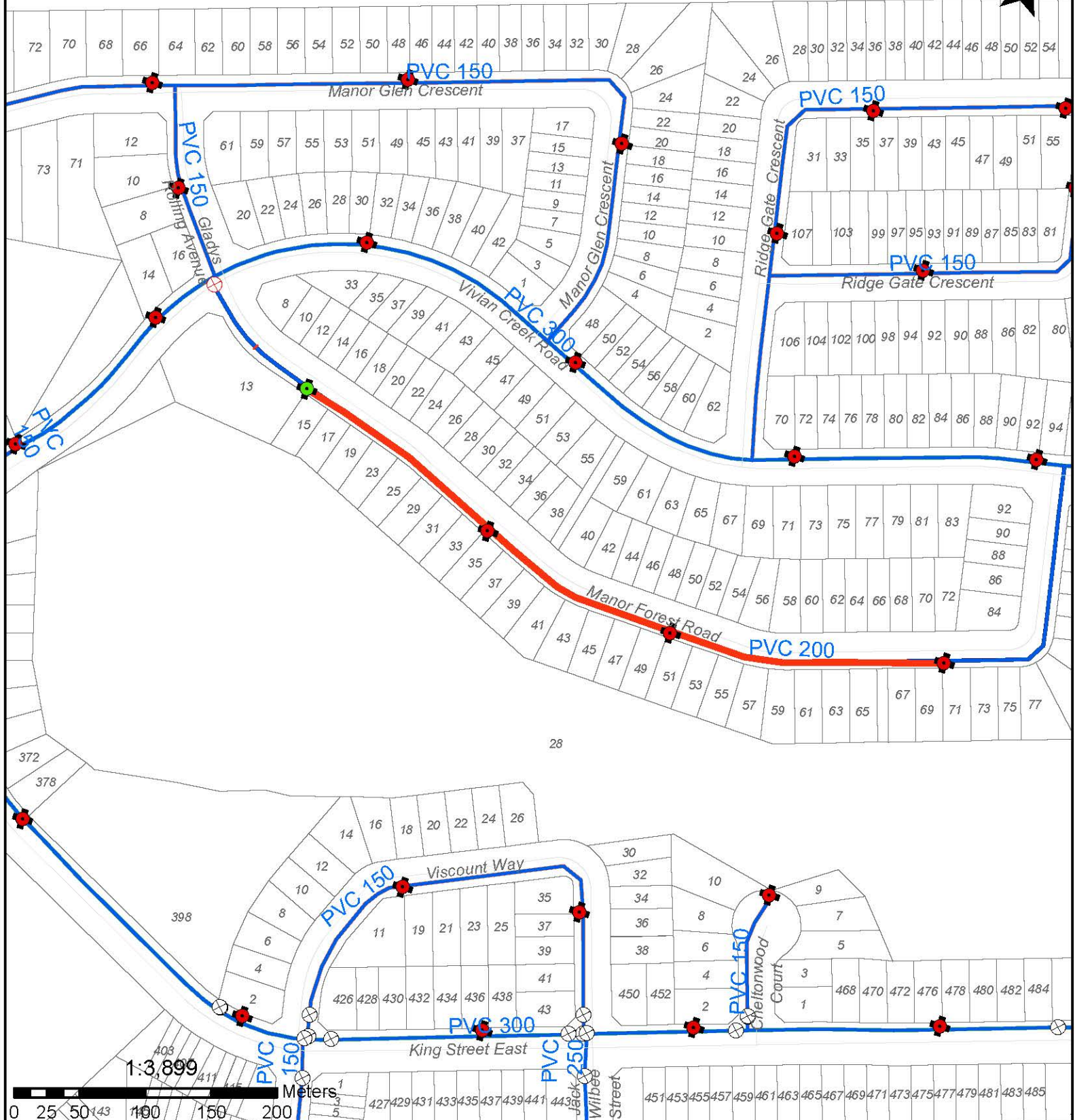

**Mount Albert Water Supply
System Upgrades
Schedule 'B' Class EA**

**Figure 6 C-factor Testing
#5 PVC 200 mm Manor
Forest Road**

Legend







- Flow Hydrant
- Hydrant
- Main Valve to be closed
- Main Valve
- Production Well
- Elevated Tank
- Test Pipes



**Mount Albert Water Supply
System Upgrades
Schedule 'B' Class EA**

**Figure 7 C-factor Testing
#6 DI 250 mm
Smauel Harper Court**

Legend



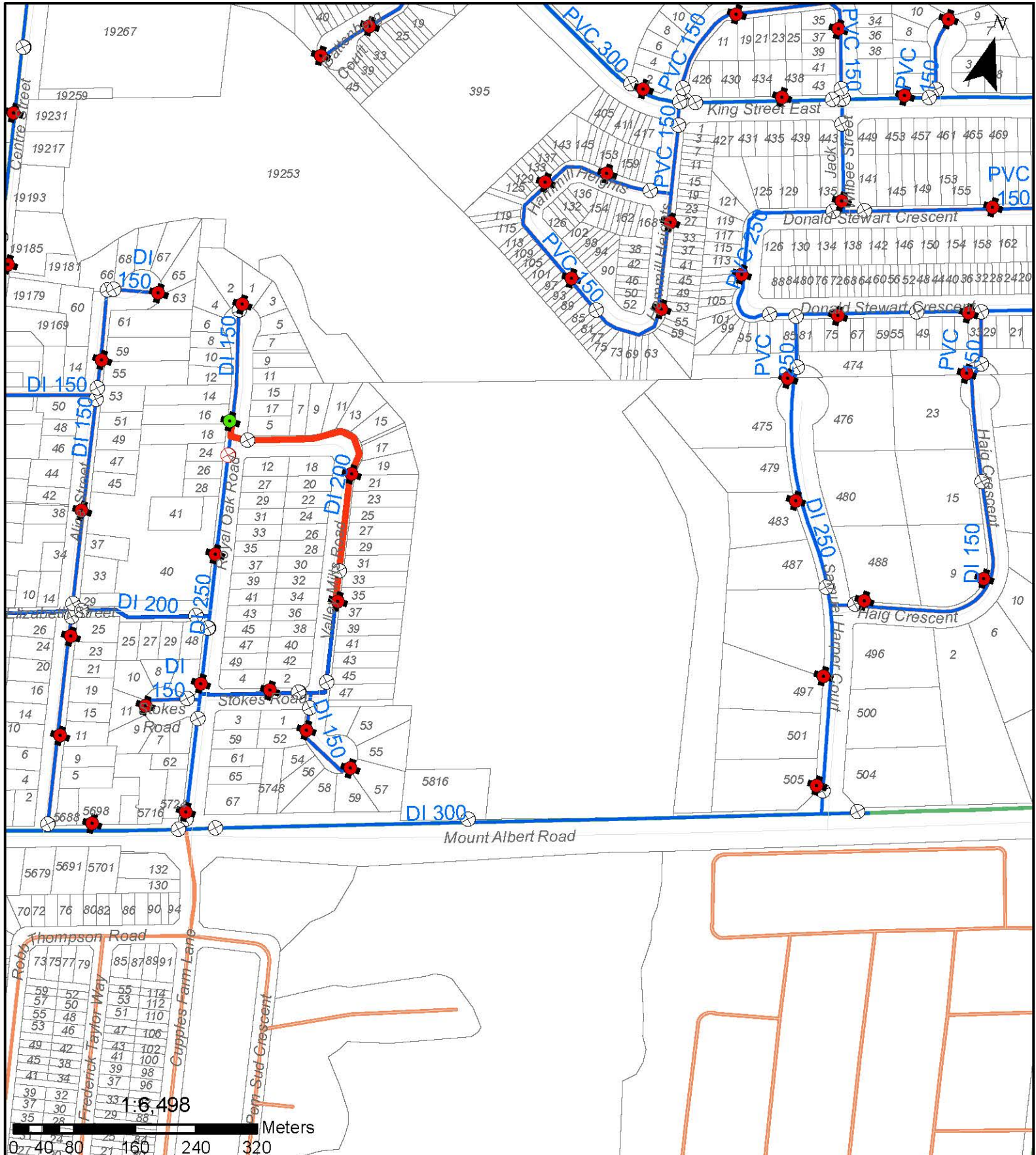



-  Flow Hydrant
-  Hydrant
-  Main Valve to be closed
-  Main Valve
-  Production Well
-  Elevated Tank
-  Test Pipes



**Mount Albert Water Supply
System Upgrades
Schedule 'B' Class EA**

**Figure 8 C-factor Testing
#7 DI 200 mm
Valley Mills Road**

Legend



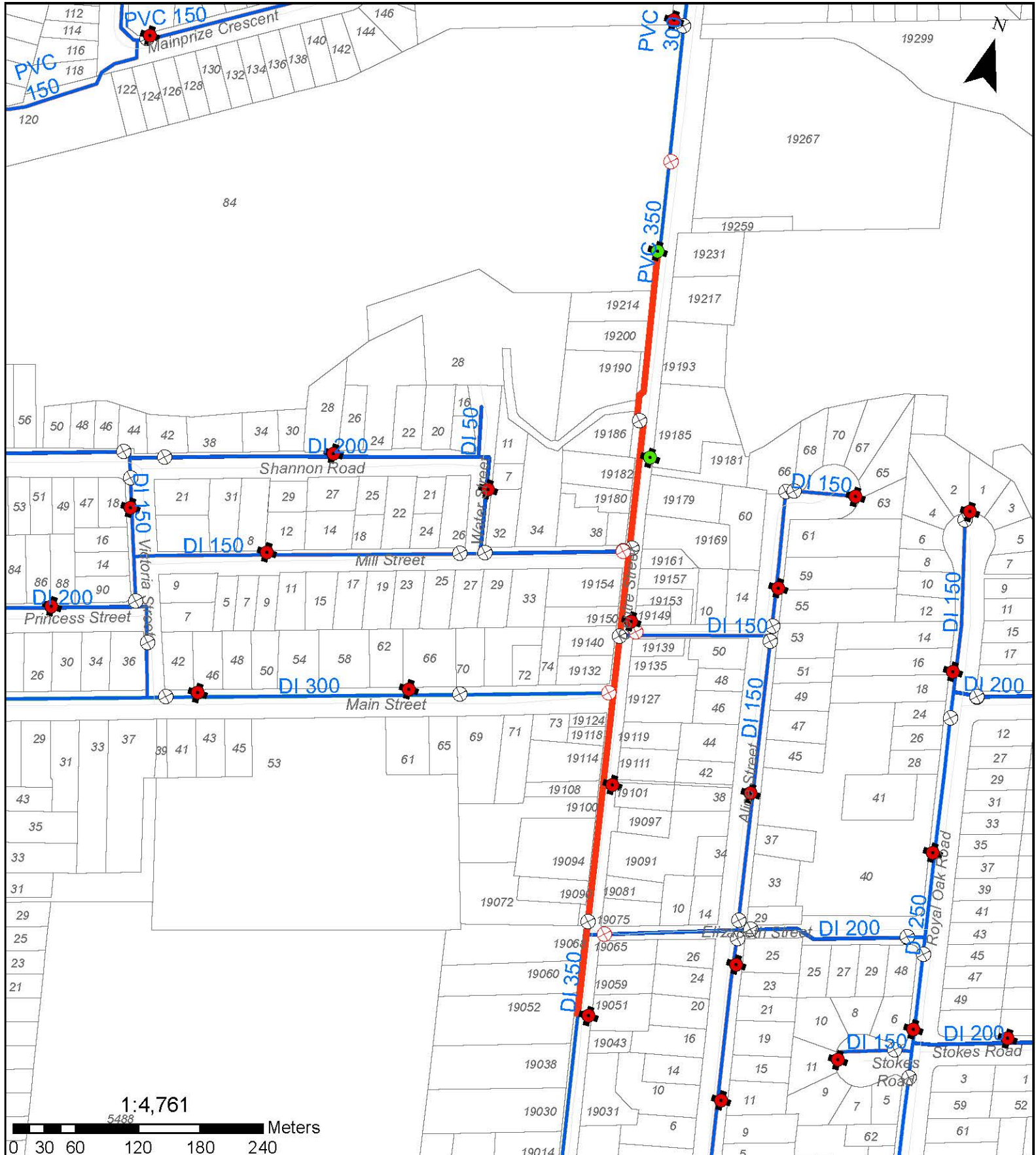



-  Flow Hydrant
-  Hydrant
-  Main Valve to be closed
-  Main Valve
-  Production Well
-  Elevated Tank
-  Test Pipes



**Mount Albert Water Supply
System Upgrades
Schedule 'B' Class EA**

**Figure 9- C-factor
Testing #8 DI 350 mm
Centre Street**

Legend

-  Flow Hydrant
-  Hydrant
-  Main Valve to be closed
-  Main Valve
-  Production Well
-  Elevated Tank
-  Test Pipes

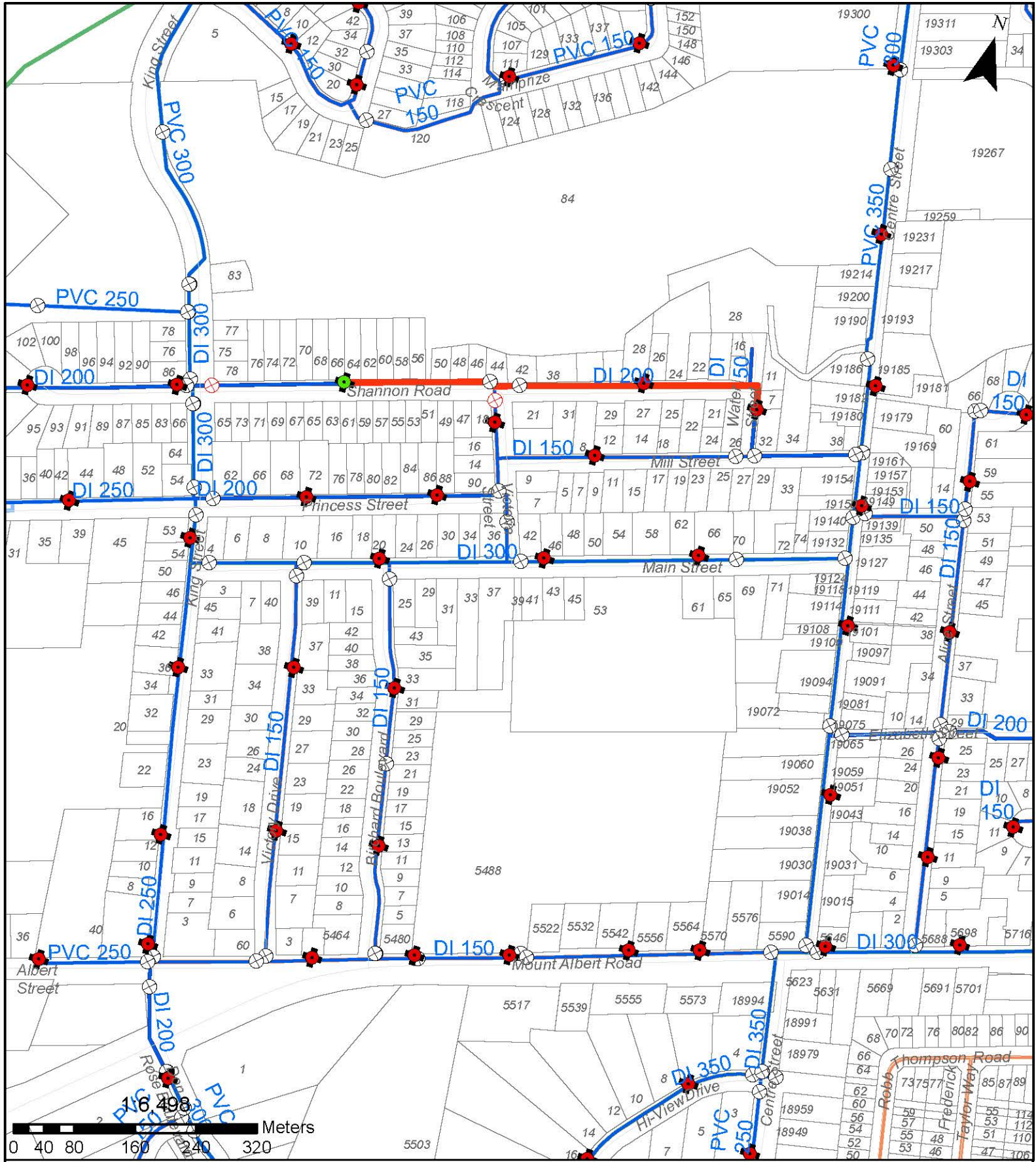

**Mount Albert Water Supply
System Upgrades
Schedule 'B' Class EA**

**Figure 10 C-factor Testing
#9 DI 200 mm Shannon
Road**

Legend



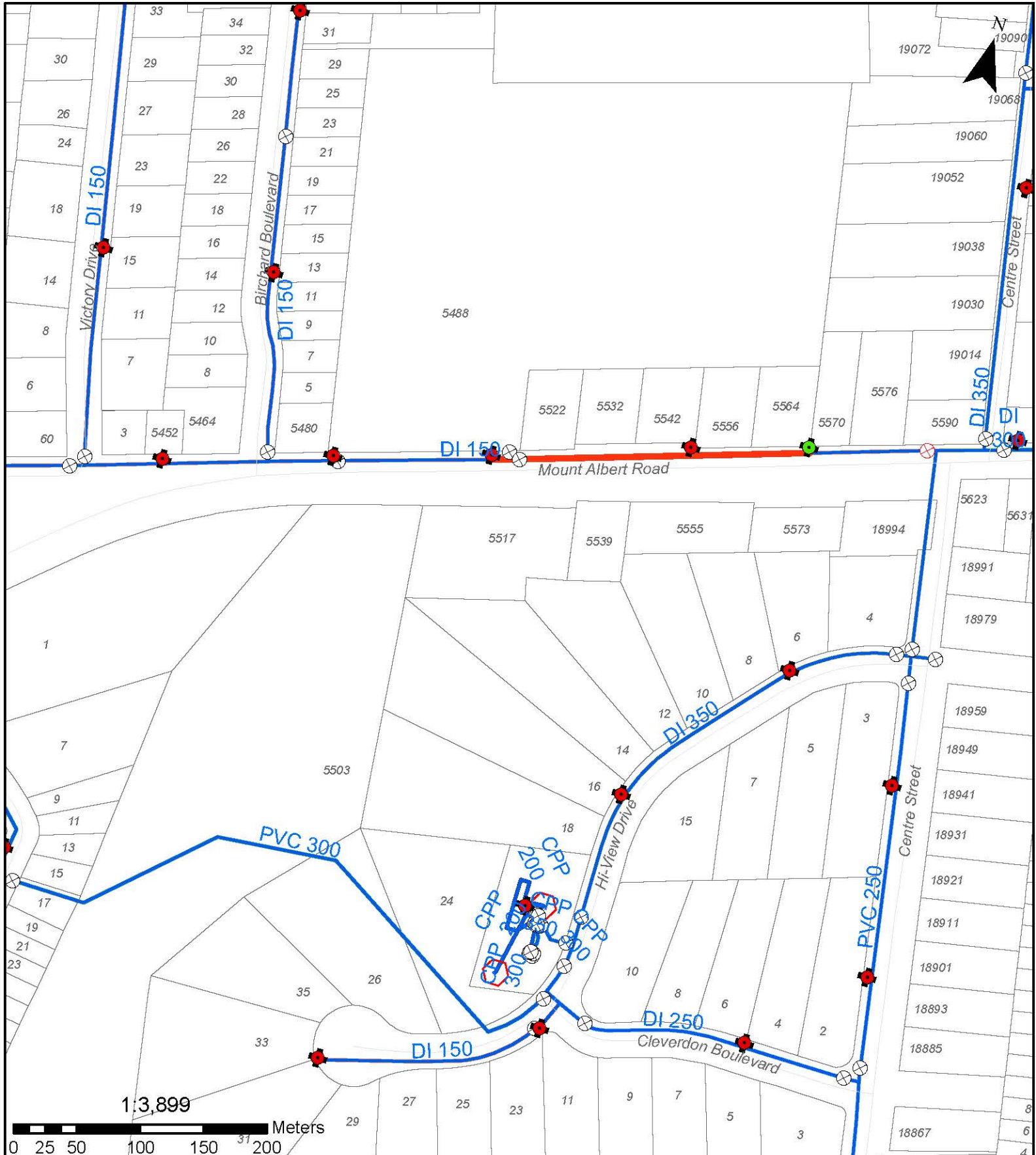



- Flow Hydrant
- Hydrant
- Main Valve to be closed
- Main Valve
- Production Well
- Elevated Tank
- Test Pipes



**Mount Albert Water Supply
System Upgrades
Schedule 'B' Class EA**

**C-factor Testing #10
DI 150 mm
Mt Albert Road**

Legend

-  Flow Hydrant
-  Main Valve to be closed
-  Hydrant
-  Main Valve
-  Production Well
-  Elevated Tank
-  Test Pipes

The procedure used to determine the Hazen-Williams "C" coefficient is as follows:

- With the Town's Operational staff assistance, identify and close required valves. Watermark will then acoustically listen on the closed valve to check the validity of the isolation.
- Install a pressure gauge and pressure logger onto both identified residual pressure test hydrants. The slope of total head will be defined with the difference of the two static pressures. These hydrants will be located at either end of the test segment and monitored by Watermark's field crew throughout the testing. Watermark will capture individual site data with the use data loggers; this enables each site to be documented electronically.
- Communication is established through the use of two-way radios; each of the three hydrant attendants and ideally the operations staff will have radios.

The testing begins with one port fully open to achieve a minimum headloss of 10 psi as per AWWA M32 guidelines. A diffuser is installed to reduce the impact of the flow to local property and water is dechlorinated to reduce the impact on natural water bodies. A Pitot tube is then inserted into the centre of the flow stream; a certain pressure reading on the gauge corresponds to a certain flow rate. The flow rate calculation is:

$$Q = 29.83cd^2\sqrt{p}$$

Where: Q is the flow in gpm
 c is the nozzle coefficient (shape of hydrant nozzle)
 d is the outlet diameter in inches
 p is the pitot reading in psi

Note: units will be converted to metric for reporting.

- As soon as a stable flow rate is achieved, the residual pressures are delivered via radio and recorded.
- The test is repeated using two diffusers, the third and fourth tests using a combination of 1-3/4" or 1-1/8" nozzles. The resulting numbers are plotted on a custom graph that is exponentially raised to 1.85, eliminating the curve and allowing staff to quickly identify if the testing was accurate.
- The "C" factor is generated from the average of all four or more tests. A full report is delivered within days, which includes a highly accurate c-factor as determined from the pressure logger data.

3. Pressure Testing

The eight locations selected for pressure testing are identified in Figure 12 and in Table 3. These locations were selected in such a way that are uniformly distributed within the water distribution system including the highest locations (near the North Elevated Tank and near Wells 1 and 2) and the lowest location (west end of Shannon Road). The change in pressure during the day and the corresponding pressure drop during the Fire Flow Testing and C-Factor Testing will be captured through the Pressure Testing at all selected locations.

Table 3: Pressure Testing Hydrants

Pressure Test Hydrant Label	Hydrant Asset ID
PT No. 1	FH397
PT No. 2	FH630

Pressure Test Hydrant Label	Hydrant Asset ID
PT No. 3	ID Not Available
PT No. 4	FH644
PT No. 5	FH63
PT No. 6	FH133
PT No. 7	FH2
PT No. 8	FH131

Watermark has provided the detailed description of the pressure Testing procedure as follows:

- Coordinate with operations staff for assistance with hydrant operation. If permission is granted, Watermark can operate and install data loggers. For installation on a fire hydrant, an adapter will be used, and the hydrant bagged “Out of Service”.
- Record pressure at 1-minute intervals for a period of no less than 21 days. This will provide the “low”, “high” and “average” pressures for typical day.
- Remove data loggers and connection modifications
- Download recorders

The reporting will include low, average, and high pressures and pressure graphs for each hydrant tested.

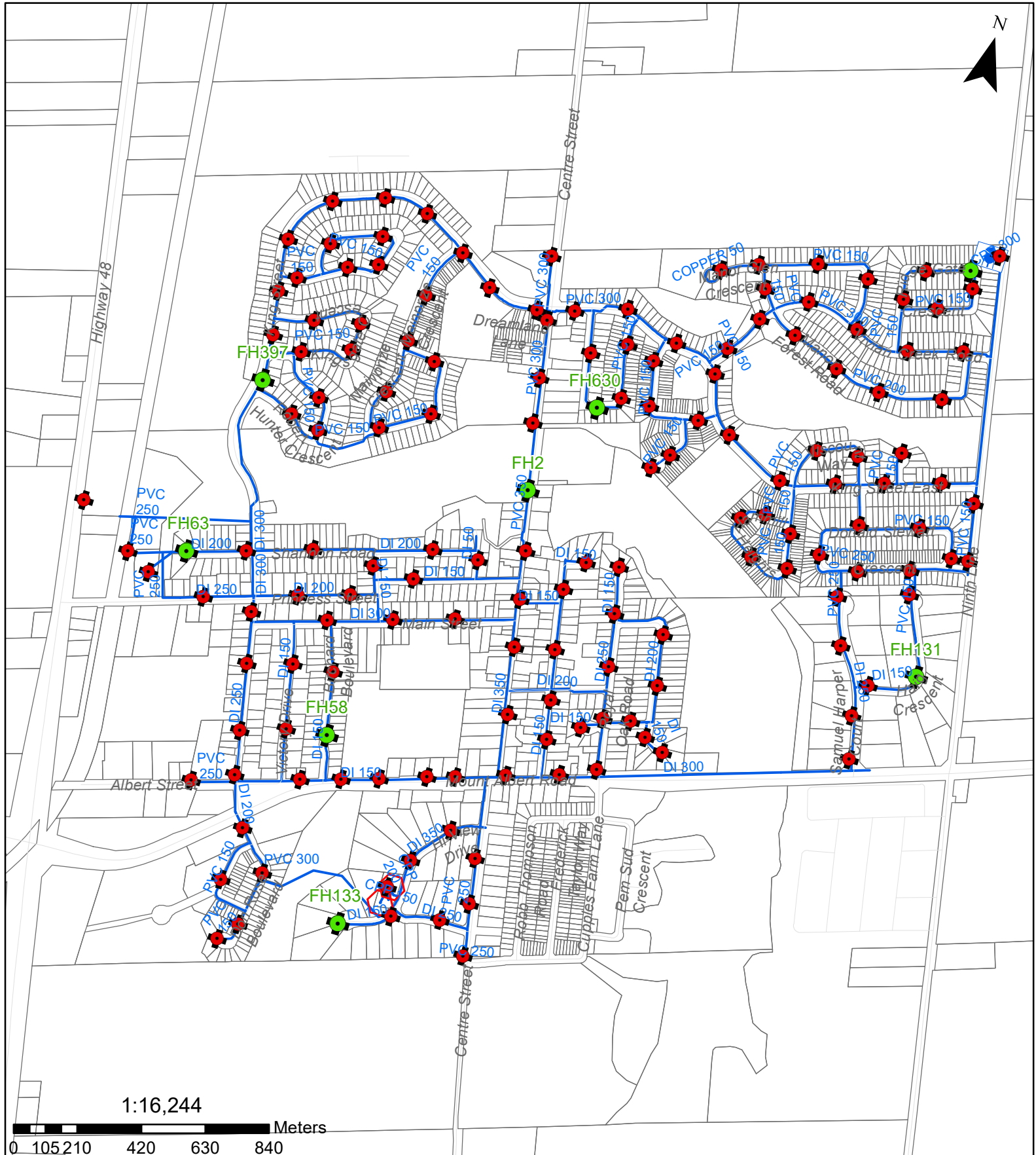





1:16,244
 0 105 210 420 630 840 Meters

**Mount Albert Water Supply
 System Upgrades
 Schedule 'B' Class EA**

Figure 12 - Pressure Testing

Legend

	Pressure Testing Hydrant		Production Well
	Hydrant		Elevated Tank

4. Coordination and Public Notice

Assistance from Town of East Gwillimbury operations is required for this testing. Specific tasks that will require operator assistance include:

- Operation of hydrants for fire flow, C-Factor and pressure testing
- Operation of valves for C-Factor testing

The field test schedule will be as follows:

- Day 1 – Install Pressure Loggers (10 hydrants)
- Day 4 – Conduct Fire Flow Testing (10 locations, 20+ hydrants)
- Day 5 – Conduct C-Factor Testing (10 locations, 30+ hydrants, plus valve operation)
- Day 11 – Remove Pressure Loggers (10 hydrants)

Jacobs will lead the coordination for this testing. The key contacts are listed in Table 4.

Table 4: Fire Flow and C-Factor Testing Key Coordination Contact

Team Member	Role	Contact Information
Luis Carvalho	York Region - Project Manager	Tel: 1 877 464-9675 ext. 75015 Email: Luis.Carvalho@york.ca
Courtney Munro	York Region - Special Project Technologist	Tel: 1 877 464-9675 ext. 77615 Email: courtneyrose.munro@york.ca
Erin Wilson	York Region – Water Resources Monitoring	Tel: 1 877 464-9675 ext. 76052 Email: erin.wilson@york.ca
Herwin Sarmiento	York Region – Supervisor Operations Maintenance and Monitoring	Tel: 1 877 464-9675 ext. XXXX Email: herwin.sarmiento@york.ca
Larry Hollett	Town of East Gwillimbury – Director of Operations	Tel: 905-478-4283 ext. 3850 Email: lhollett@eastgwillimbury.ca
Matthew Hemingway	Town of East Gwillimbury – Environmental Operations Technologist	Tel: 905-478-4283 ext. 3477 Email: mhemmingway@eastgwillimbury.ca
Allanna Yahoda	Jacobs Assistant Project Manager	Tel: 1 416-499-0090 ext. 73652 Email: allanna.yahoda@jacobs.com
Mauricio Rojas	Jacobs Hydraulic Analysis Lead	Tel: 1 416-499-0090 ext. 73698 Email: mauricio.rojas@jacobs.com
Colin Powell	Watermark Project Manager	Tel: 1-647 494-3003 Email: colin.powell@watermark.ca
Rob Gamache	Watermark Project Manager	Email: rob.gamache@watermark.ca

EG noted that in anticipation to low pressure and/or red water complaints during operation and testing of hydrants, 2-weeks notice to the Mount Albert customers and the public will be required. EG also noted that hydrant testing may be performed between the hours of 9:00 am and 3:00 pm in order to avoid disturbing the watermains during peak user demand hours.

It was also noted that no hydrant testing is to be done on Mondays (or first day back following a Statutory Holiday), given that this normally is the day that the Town takes the BAC samples.=

5. Next Steps

Jacobs to coordinate with East Gwillimbury, Region of York and Watermark.



Memorandum

Hydraulic Analysis Study

Appendix C

Water Quality Sampling Plan, July 26, 2019

245 Consumers Road, Suite 400
Toronto, Ontario M2J 1R3
Canada
T +1.416.499.9000

www.jacobs.com

Subject	Water Quality Sampling Plan	Project Name	Mount Albert Water Supply System Upgrades
Attention	Region of York, Town of East Gwillimbury	Project No.	CE731500
From	Jacobs		
Date	July 26, 2019		
Copies to			

To support the water quality modelling being conducted for the Mount Albert drinking water system as part of the EA, Jacobs will coordinate and conduct chlorine, pH, and temperature sampling at the well facilities to determine the bulk water chlorine decay rate and throughout the distribution system to determine how chlorine concentrations vary across the system over the course of 24 hours. This information will be used to calibrate the water quality model. For the Region's consideration a sampling plan for distribution system iron and manganese is being submitted separately, if accepted by the Region, it will be incorporated in the overall water quality sampling plan.

1. Sample Locations

There are three distinct water quality sampling tasks: bulk decay sampling and distribution system sampling for chlorine and for iron and manganese.

1.1 Bulk Decay Sampling

At the well facilities (two locations, Well 1&2 Facility and Well 3 Facility) samples of the water will be collected for bulk decay testing. Only Wells 2 and 3 will be sampled as Well 1 is not currently used.

1.2 Distribution System Sampling

The samples for the distribution chlorine residual measurement will be collected at various locations throughout the distribution system. Based on a review of the preliminary system model, Jacobs has identified the locations best suited for this sampling. The locations were selected to provide coverage of the distribution system to identify how the water quality changes with factors such as water demands, distance from wells, storage tanks, and distribution mains. Areas of reported existing water quality complaints are covered in the locations selected for sampling. The sampling locations cover a range of flow rates, pipe diameters, pipe ages and pipe materials. The conditions at these locations range from worst-case (old pipes with low-flow conditions) to best case (new pipes with high flow). The sample locations are distributed across the system, so sampling will also cover a range of water ages. The distribution chlorine residual testing sample locations are identified in Table 1-1 and Figure 1-1.

Table 1-1. Distribution Sample Locations

Sample Location Number	Address	Type
1	126 Mainprize Crescent	Exterior Sampling Station
2	19451 Centre St	Exterior Sampling Station
3	405 King St E	Exterior Sampling Station
4	74 Manor Glen Crescent	Exterior Sampling Station
5	Millennium Park at King St and Albert St	Exterior Sampling Station
6	5517 Mt Albert Rd	Exterior Sampling Station
7	18855 Centre St	Exterior Sampling Station
8	19178 Ninth Line	Elevated Tank

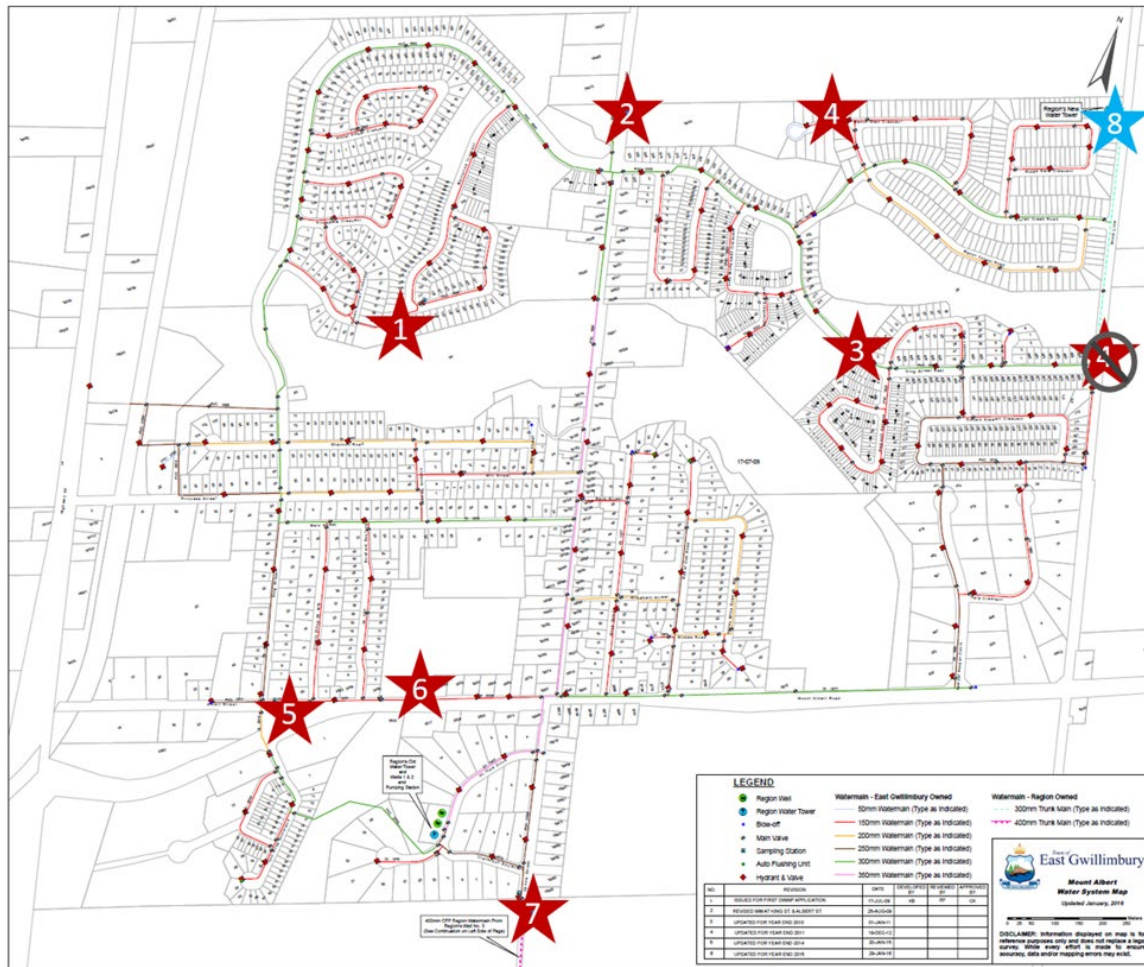

Figure 1-1 Distribution System Sample Locations

Red = Sampling station, Blue = water tower, sample location 4 relocated from previous per discussion with Town of East Gwillimbury and Region

The sample location details are shown in Table 1-2. Predicted pipe velocity values are from preliminary modelling done by Jacobs.

Table 1-2. Sample location details

Sample Location Number	Pipe Material	Pipe Diameter (mm)	Pipe Age	Predicted Pipe Velocity (m/s during pump operation)
1	PVC	150	1995	0 to 2.3
2	PVC	300	1995	0 to 2.3
3	PVC	300	2002	32 to 54
4	PVC	150	2010-2016	0 to 2.3
5	DI	150	1977	2.3 to 7.7
6	DI	150	2006	0 to 2.3
7	PVC/concrete pressure pipe	250	1979	32 to 54
8	NA	NA	NA	NA

2. Sample Collection and Testing

2.1 Bulk Decay Sampling

For the bulk decay analysis, eight (8) samples of 500 mL each will be collected in chlorine demand free amber glass bottles at each well facility. Coordination with the Regional Municipality of York (Region) staff will be required for access to the facilities and indication of best location in well facility to obtain treated water samples. Sampling will begin after the well facility has begun operating to allow the water quality to stabilize.

Region has noted that for Well 2, at typical operating flows, it will take approximately 70 minutes for treated water to reach the tap after well start up ($90.48 \text{ m}^3 \times 1000 / 24 \text{ L/s} / 60 = 63 \text{ min}$ HRT plus turnover of sample line (contact tank sized for 2 wells at PTTW capacity)). Well 3, at typical operating flows will take approximately 20 minutes (HRT in the contact tank of 14.73 min, add 5 min process lag to sample tap). The Region therefore recommended to sample at Well 3 first, Jacobs is in agreement with this recommendation. The sampler will ensure that the bottles are filled such that there is no headspace when the bottle is sealed. The bulk decay testing will be performed partially in the field and at Jacobs offices. The free chlorine concentration will be measured at 0, 0.5, 1, 2, 4, 6, 24, 48 and 72 hours, with 2 measurements performed at each time interval (to provide duplicate measurements). Collected samples will be stored in an insulated container between measurements to minimize exposure to light and temperature fluctuations.

Initial measurements will be conducted for the water temperature of the well, at the well facility. The water samples will then be transported back to the Jacobs office where they will be stored in a temperature-controlled room, allowing the sample temperature to gradually increase to 18 °C. Free chlorine and total chlorine analyses will be performed using a HACH SL 1000 handheld device.

Where possible, the same staff will be used to conduct analyses to minimize analytical variability. Instruments will be supplied by the Region and Pine Environmental and will be calibrated before delivery. Documentation for the calibration will be required and included with the test results.

2.2 Distribution System Chlorine Sampling

For the distribution chlorine residual testing, ten samples will be collected at each sample location (eight locations) over two separate 24-hour periods that will be coordinated with the Region and the Town of East Gwillimbury operations staff. All eight sampling locations will be tested in each 24-hour period thereby providing duplicate measurements for analysis. Measurements of free chlorine, total chlorine, pH and temperature will be conducted with portable instruments in the field. The exact time of sampling will be recorded for each measurement so that the data can be incorporated into the model accurately. Field blanks filled with distilled water and tested in the laboratory for chlorine, pH, and temperature with the same portable instruments for each of the 10 sampling events over the 24 hour period will be used. The field blanks will be transported in a cooler with blue ice to each of the 8 sites and retested for chlorine, pH, and temperature sampling event. These will be used to evaluate potential problems with the portable instrument's calibration and potential cross contamination. During sampling, all sites will have duplicate samples taken and analyzed for free chlorine and total chlorine, as part of the quality assurance program.

Free and total chlorine measurements, done in duplicate will utilize a Hach SL 1000 handheld device. pH and temperature measurements will utilize a pH probe in a flow-through cell. Where possible, the same staff will be used to conduct analyses to minimize analytical variability. Instruments will be supplied by the Region and Pine Environmental and will be calibrated before delivery. Documentation for the calibration will be required and included with the test results.

In order to conduct these analyses on 10 samples at eight locations, measurements will be taken at each location at roughly 2-hour intervals. The sampling plan allows for 15 minutes per sampling event, including: travel between sampling locations, sample collection, measurement, and recording of pH, free chlorine and temperature. A blank data collection sheet is attached at the end of this document.

Note that this scheduling assumes that once the monitoring station sample locations are set up, they can be left flowing at a low rate so that they do not need to be flushed before every sampling event.

For the first scheduled 24-hour sampling event, the sampling will commence at 10:00 AM on day one and conclude around noon on the following day. Wells 2 and 3 should begin operation 1 hour before sampling begins (9:00 AM) and should operate for 8 hours (5:00 PM) or until the water tower has sufficient water to supply the town for the remainder of the distribution testing.

For the first second 24-hour sampling event, the sampling will commence at 10:00 AM on day one and conclude around noon on the following day. Wells 2 and 3 will be operated over the previous night such that the end of the fill cycle is approximately 9:00 AM, one hour before the start of sampling.

2.3 Distribution System Iron the Manganese Sampling

The iron and manganese sampling will be performed in the second 24 hour period of the chlorine residual testing. The distribution system chlorine residual testing sample locations will be the same locations used for the distribution system iron and manganese sample testing. A filtered and unfiltered sample at each sampling location per sampling event will be collected. Samples will be collected for the following sampling events to include the late fill, early drain, middle drain, and late drain portions of a typical fill/drain cycle to see how the results vary from freshly treated water to water with a higher water age:

- Approximately one hour before fill cycle ends;
- Approximately one hour after a fill cycle ends;
- At around 12 h into the drain cycle; and,
- At around 24 h into the drain cycle

Each sample will be tested for turbidity, and total and dissolved iron and manganese (therefore unfiltered and filtered samples will be required). Duplicates for iron and manganese (total and filtered) will be taken at 2 of the sampling locations in each of the 4 sampling events (providing duplicates for 25% of samples), as part of the quality assurance program. The sample size required for ICP-MS is 50 ml. A 60 ml syringe with a 0.45 µm syringe filter will be used to filter the sample at the time of collection. This filtering approach was chosen to minimize the potential of oxidizing the sample, and for ease during field execution. Filter papers will be kept and catalogued to compare against the results obtained from the laboratory analysis. One field blank, filled with distilled water, will be used for each of the 3 sampling events. The total number of samples collected will be 66 (33 filtered, 33 unfiltered). Turbidity will be measured and recorded in the field using a portable turbidimeter such as a Lamotte 2020 or a Hach 2100.

3. Coordination

Assistance from the Town of East Gwillimbury Operations and York Region Operations staff will be required for this sampling. We propose a coordination call to revise the plan as appropriate, the current assumptions are as follows:

- Region – For bulk decay sampling, assistance from Region Operations staff will be required for access and operation of sample ports in the well facility and water tower sites.
- Town of East Gwillimbury – For chlorine residual testing, assistance from Town of East Gwillimbury is required to operate the sample stations.

The current test plan for the distribution water quality sampling envisions using three consecutive shifts for Jacobs staff working alongside Region/East Gwillimbury staff to conduct the sampling. It is requested that the Region/East Gwillimbury indicates hours of availability of staff for accessing well houses, sampling at the North elevated tower, and operation of the sampling stations. Any information/constraints related to accessibility of the sampling locations is also requested. Table 3-1 indicates the proposed distribution system water sampling schedule for the first 24 hour period. Table 3-2 indicates the proposed distribution system water sampling schedule for the first 24 hour period. Table 3-3 is the contact list for the sampling period.



Memorandum

245 Consumers Road, Suite 400
 Toronto, Ontario M2J 1R3
 Canada
 T +1.416.499.9000

www.jacobs.com

Table 3-1 Proposed distribution system water quality sampling schedule first 24 hour period

Time	Task	Attendees	Notes
Day 1: 8:00 AM	Convene at Mount Albert Well 1&2 Facility for a tailgate meeting and prepare equipment and sample locations (get access and sample flowing at all 8 stations). Also commence operating well facilities at this time to refill north water tower.	East Gwillimbury: Operations Region: Operations Jacobs: Dave Scott (Chairing Meeting)	
Day 1: 9:00 AM	Commence operating well facilities at this time to refill north water tower. Allow Well 3 to operate for approximately 20 minutes and then collect sample for bulk decay test.	East Gwillimbury: Operations Region: Operations Jacobs: Dave Scott	
Day 1: 10:00 AM	Begin official 24 hours of distribution system sampling.	East Gwillimbury: Operations (on call) Region: Operations Jacobs: Dave Scott	
Day 1, 5:00 PM	Cease operating well facilities at this time (Duty 1 stop if ET is full). Unless required, Region to ensure that well facilities do not operate for the rest of the distribution sampling.	East Gwillimbury: Operations (on call) Region: Operations Jacobs: Dave Scott overlap with Mark Spanjers	
Day 1: 6:00 PM	End of shift for first Jacobs crew, start of shift for second Jacobs crew.	East Gwillimbury: Operations requested to meet with Region Operator around 7:30 PM to review procedures if adverse observed Region: Operations Jacobs: Mark Spanjers	(10-hour shift)

Time	Task	Attendees	Notes
Day 2: 2:00 AM	End of shift for Jacobs second crew, start of shift for third Jacobs crew	East Gwillimbury: Operations (on call) Region: Operations Jacobs: Dave Scott overlap with Mark Spanjers	(9-hour shift)
Day 2: Noon	End of 24-hour test period. Shut down sample taps and secure sample locations. Confirm all notes and paperwork in order before leaving.	East Gwillimbury: Operations (on call) Region: Operations Jacobs: Dave Scott overlap with Mark Spanjers	(10-hour shift)

Table 3-2 Proposed distribution system water quality sampling schedule second 24 hour period

Time	Task	Attendees	Notes
Day 1: 8:00 AM	Convene at Mount Albert Wells 1&2 Facility for a tailgate meeting and prepare equipment and sample locations (get access and sample flowing at all 8 stations). Coordinate with Region Operations to have fill cycle started approximately at 6:00 AM.	East Gwillimbury: Operations Region: Operations Jacobs: Dave Scott (Chairing Meeting)	
Day 1: 9:00 AM	Begin official 24 hours of distribution system chlorine sampling.	East Gwillimbury: Operations (on call) Region: Operations Jacobs: Dave Scott	
Day 1: 2-4: PM	Monitor tower level, once fill cycle is nearing end (approximately 1-2 hours before fill cycle complete), take first iron and manganese sample	East Gwillimbury: Operations (on call) Region: Operations Jacobs: Dave Scott	First iron and manganese sampling event
Day 1: 6:00 PM	End of shift for first Jacobs crew, start of shift for second Jacobs crew. Monitor tower level, approximately 1 hour into the drain cycle, take second iron and manganese sample	East Gwillimbury: Operations requested to meet with Region Operator around 7:30 PM to review procedures if adverse observed Region: Operations	(10-hour shift) Second iron and manganese sampling event

Time	Task	Attendees	Notes
		Jacobs: Dave Scott overlap with Mark Spanjers	
Day 1: 10:00 PM	Collect iron and manganese samples, third iron and manganese sample	East Gwillimbury: Operations (on call) Region: Operations Jacobs: Mark Spanjers	Third iron and manganese sampling event
Day 2: 2:00 AM	End of shift for Jacobs second crew, start of shift for third Jacobs crew	East Gwillimbury: Operations (on call) Region: Operations Jacobs: Dave Scott overlap with Mark Spanjers	(8-hour shift)
Day 2: Noon	End of 24-hour test period. Shut down sample taps and secure sample locations. Confirm all notes and paperwork in order before leaving.	East Gwillimbury: Operations (on call) Region: Operations Jacobs: Dave Scott	(10-hour shift)
Day 2: 5:00 PM	Final iron and manganese sample	East Gwillimbury: Operations (on call) Region: Operations Jacobs: Dave Scott	(2-hour shift) Final iron and manganese sample

Table 3-3 Water Quality Sampling Key Coordination Contact List - First 24-hour Sampling Period

Team Member	Role	Contact Information
Luis Carvalho	York Region - Project Manager	Tel: 1 877 464-9675 ext. 75015 Email: Luis.Carvalho@york.ca
Courtney Munro	York Region - Special Project Technologist	Tel: 1 877 464-9675 ext. 77615 Email: courtneyrose.munro@york.ca
Herwin Sarmiento	York Region – Supervisor Operations Maintenance and Monitoring	Tel: 1 905 830-4444 ext. 75167 Cell 1 905 953-6237 Email: herwin.sarmiento@york.ca
Joe Williams	Region Operator Shift 1 & 3 (8:00 AM to 7:00 PM)	Cell: 1 905 953-6246

Team Member	Role	Contact Information
Stephen Baidy	Region Operator Shift 2	Cell: 1 289 716-4725
Greg Hughson	East Gwillimbury Acting ORO	Contact: 1 905-955-5188 Email: ghughson@eastgwillimbury.ca
Steve Bowles	East Gwillimbury Operator On-call	Contact: 1 905-955-0440
Larry Hollett	Town of East Gwillimbury – Director of Operations	Tel: 1 905-478-4283 ext. 3850 Email: hollett@eastgwillimbury.ca
Matthew Hemingway	Town of East Gwillimbury – Environmental Operations Technologist	Tel: 1 905-478-4283 ext. 3477 Email: mhemmingway@eastgwillimbury.ca
Allanna Yahoda	Jacobs Assistant Project Manager	Tel: 1 416-499-0090 ext. 73652 Cell: 1 416-464-4890 Email: allanna.yahoda@jacobs.com
Dave Scott	Jacobs Water Quality Field Investigations Lead	Tel: 1 416-499-0090 ext. 73579 Cell: 1 647-999-7799 Email: dave.scott@jacobs.com
Mark Spanjers	Jacobs Process Support	Tel: 1 416-499-0090 ext. 73817 Cell: 1 519-616-2345 Email: mark.spanjers@jacobs.com

Table 3-4 Water Quality Sampling Key Coordination Contact List - Second 24-hour Sampling Period

Team Member	Role	Contact Information
Luis Carvalho	York Region - Project Manager	Tel: 1 877 464-9675 ext. 75015 Email: Luis.Carvalho@york.ca
Courtney Munro	York Region - Special Project Technologist	Tel: 1 877 464-9675 ext. 77615 Email: courtneyrose.munro@york.ca

Team Member	Role	Contact Information
Herwin Sarmiento	York Region – Supervisor Operations Maintenance and Monitoring	Tel: 1 905 830-4444 ext. 75167 Cell 1 905 953-6237 Email: herwin.sarmiento@york.ca
	Region Operator Shift 1 & 3	Cell: 1 905 953-6246
	Region Operator Shift 2	Cell: 1 289 716-4725
Greg Hughson	East Gwillimbury Acting ORO	Contact: 1 905-955-5188 Email: ghughson@eastgwillimbury.ca
Ivie Osuch	East Gwillimbury Operator	Email: iosuch@eastgwillimbury.ca
Larry Hollett	Town of East Gwillimbury – Director of Operations	Tel: 1 905-478-4283 ext. 3850 Email: lhollett@eastgwillimbury.ca
Matthew Hemingway	Town of East Gwillimbury – Environmental Operations Technologist	Tel: 1 905-478-4283 ext. 3477 Email: mhemmingway@eastgwillimbury.ca
Allanna Yahoda	Jacobs Assistant Project Manager	Tel: 1 416-499-0090 ext. 73652 Cell: 1 416-464-4890 Email: allanna.yahoda@jacobs.com
Dave Scott	Jacobs Water Quality Field Investigations Lead	Tel: 1 416-499-0090 ext. 73579 Cell: 1 647-999-7799 Email: dave.scott@jacobs.com
Mark Spanjers	Jacobs Process Support	Tel: 1 416-499-0090 ext. 73817 Cell: 1 519-616-2345 Email: mark.spanjers@jacobs.com

Appendix D

Water Quality Validation Plots

Tank Water Quality Validation

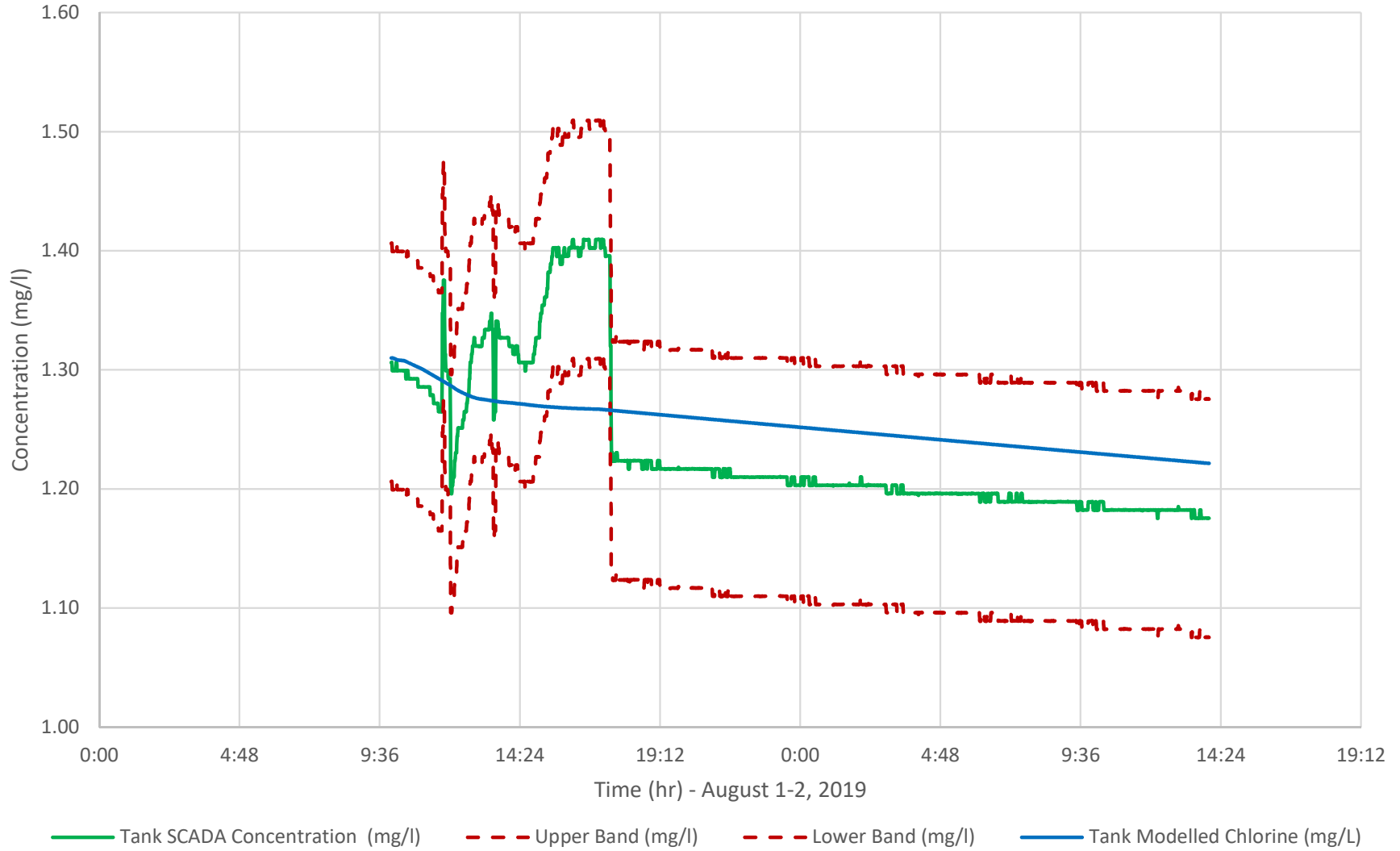

1 Mainprize Crs Water Quality Validation

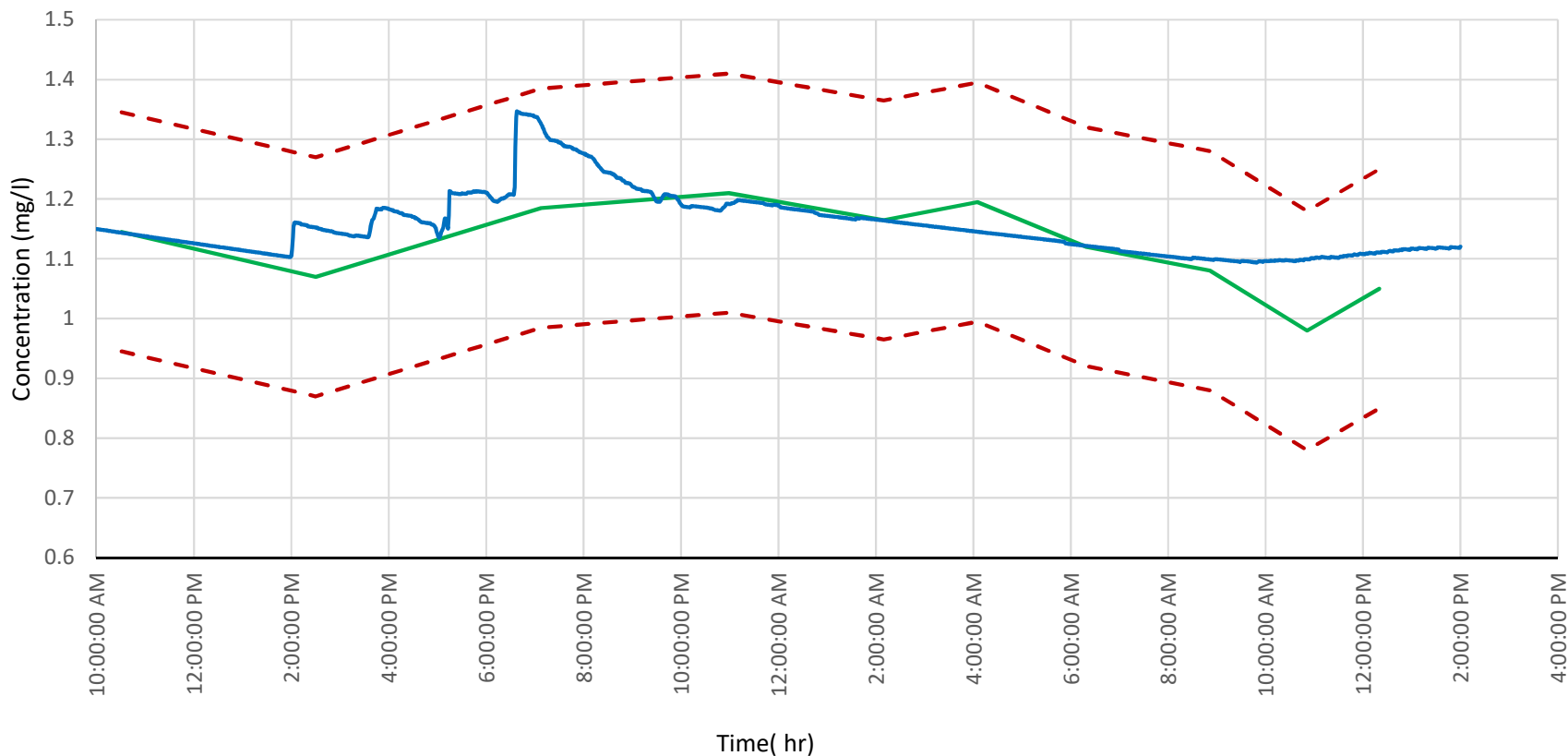

— Measured Concentration (mg/l) - - - Upper Band (mg/l) - - - Lower Band (mg/l) — Modelled Concentration (mg/l)

19451 Centre St Water Quality Validation

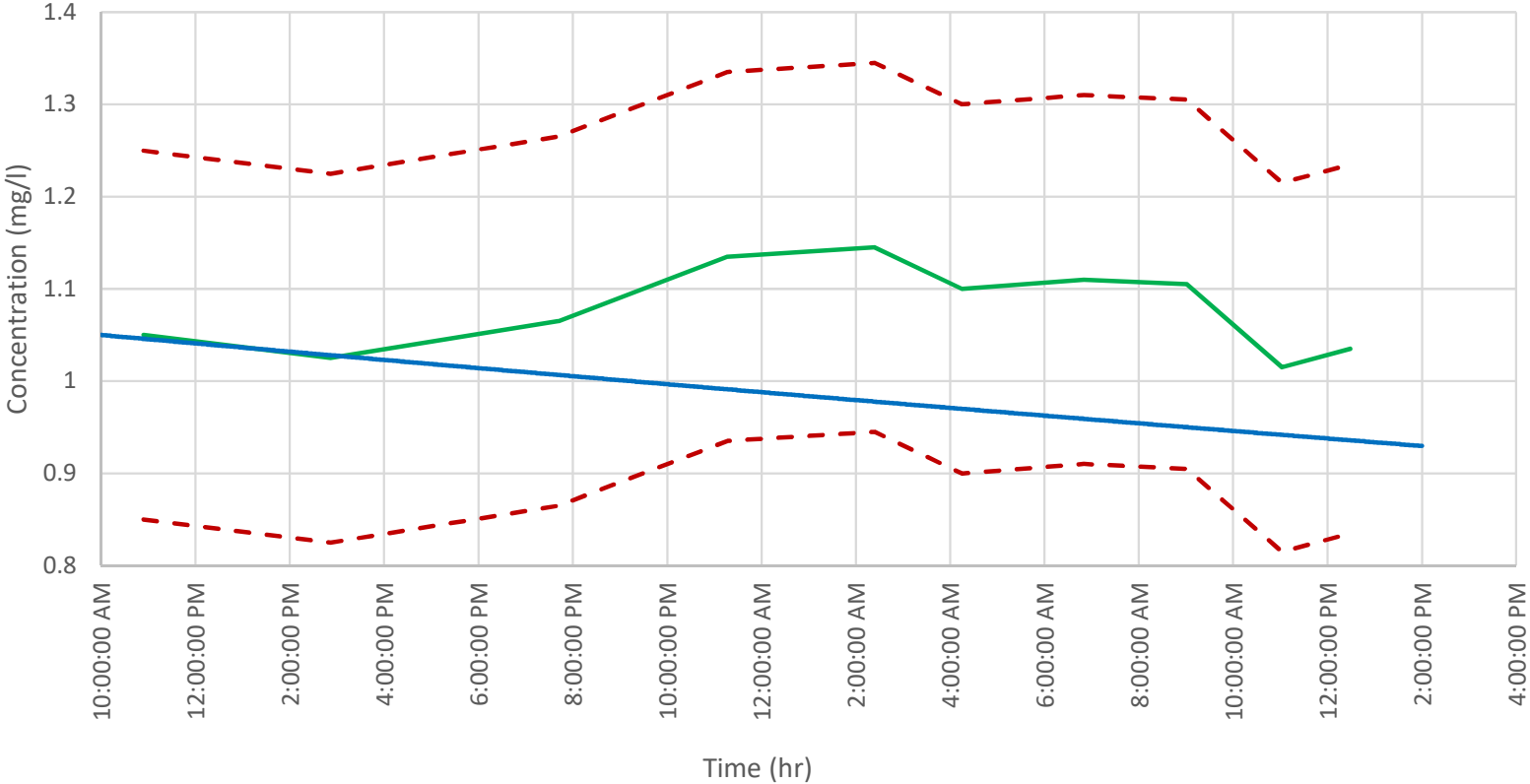

— Measured Concentration (mg/l) - - - Upper Band (mg/l) - - - Lower Band (mg/l) — Modelled Concentration (mg/l)

405 King St Water Quality Validation

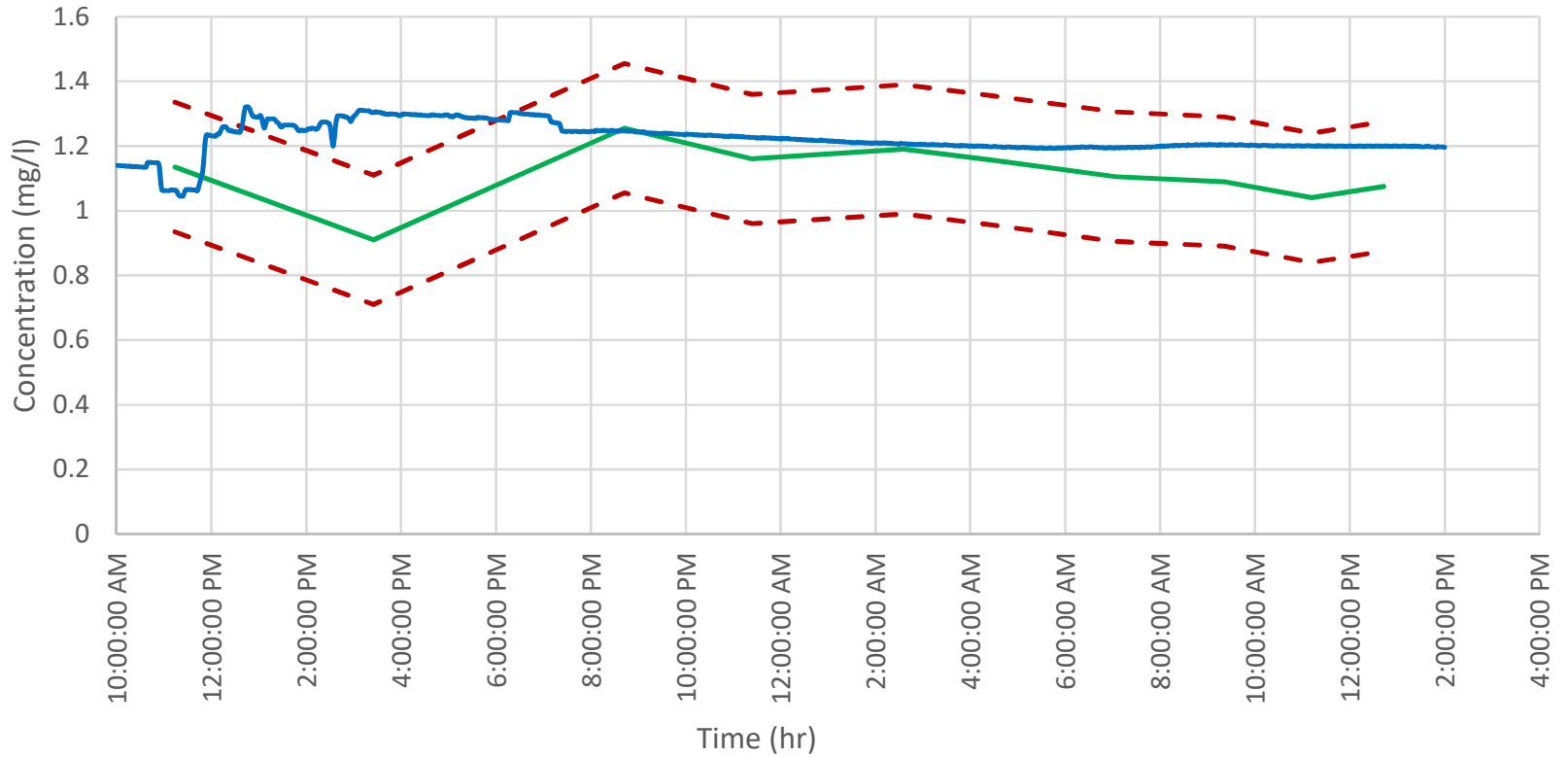

— Measured Concentration (mg/l) - - - Upper Band (mg/l) - - - Lower Band (mg/l) — Modelled Concentration (mg/l)

74 Manor Glen Crs Water Quality Validation

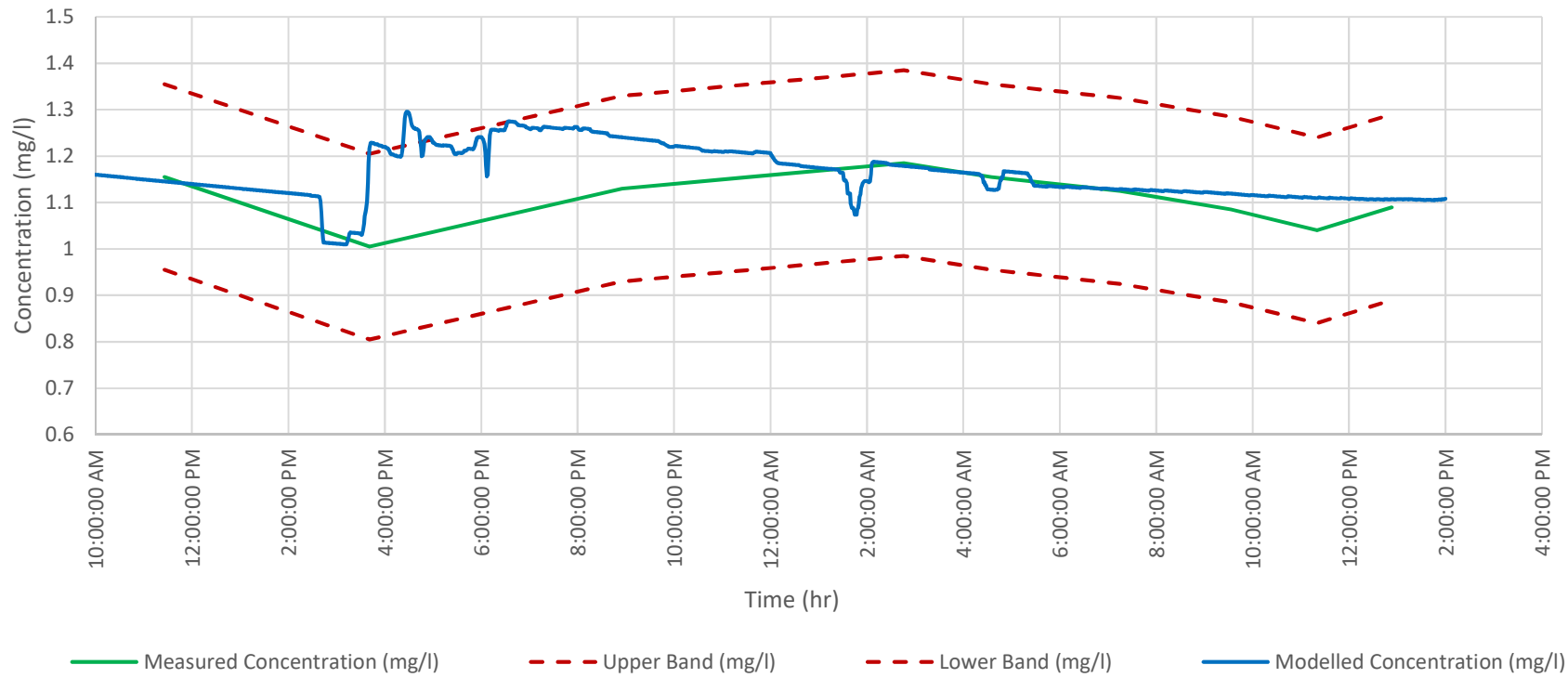

Millennium Park Water Quality Validation

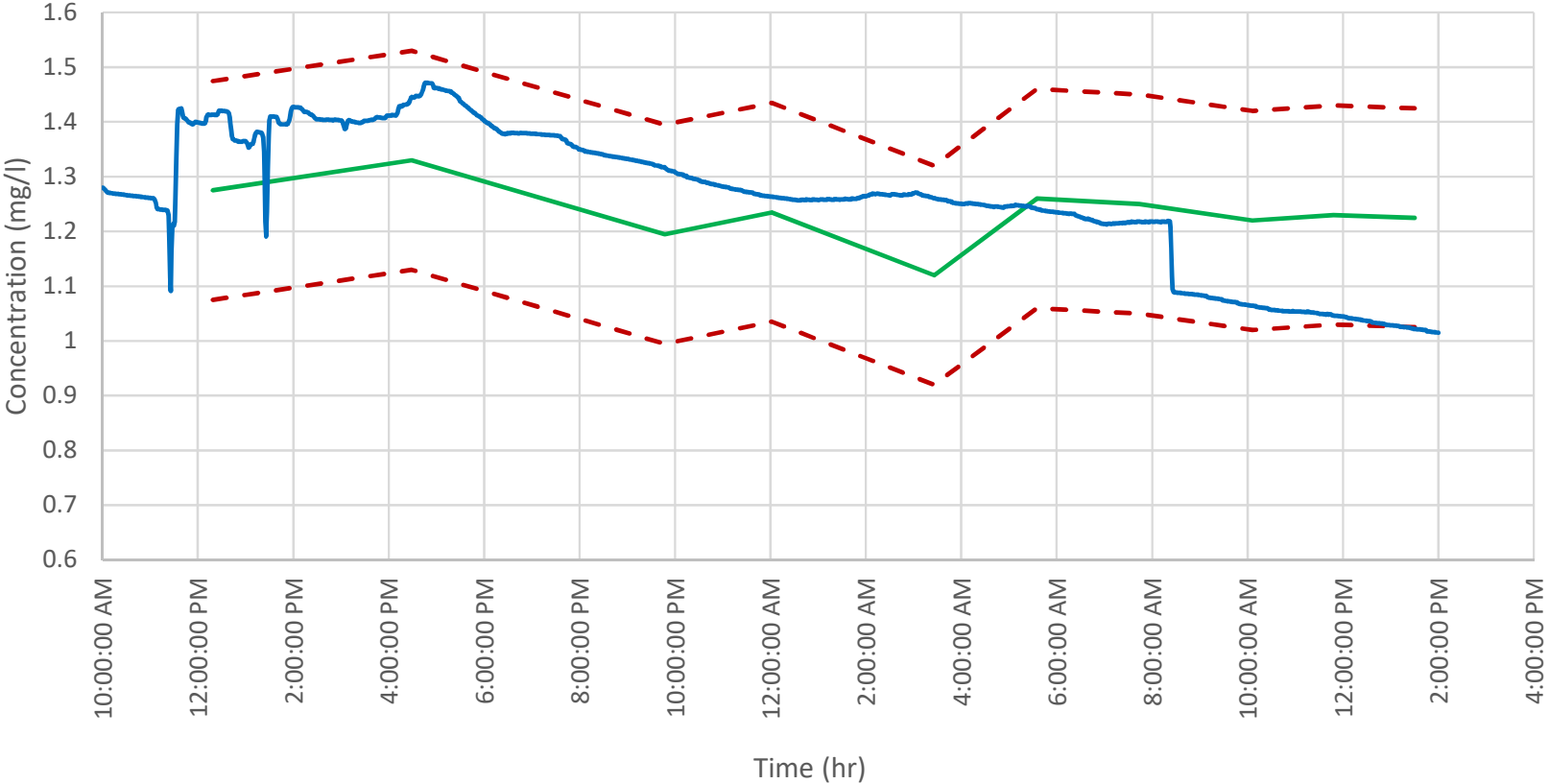

— Measured Concentration (mg/l) - - - Upper Band (mg/l) - - - Lower Band (mg/l) — Modelled Concentration (mg/l)

5517 Mt Albert Rd Water Quality Validation

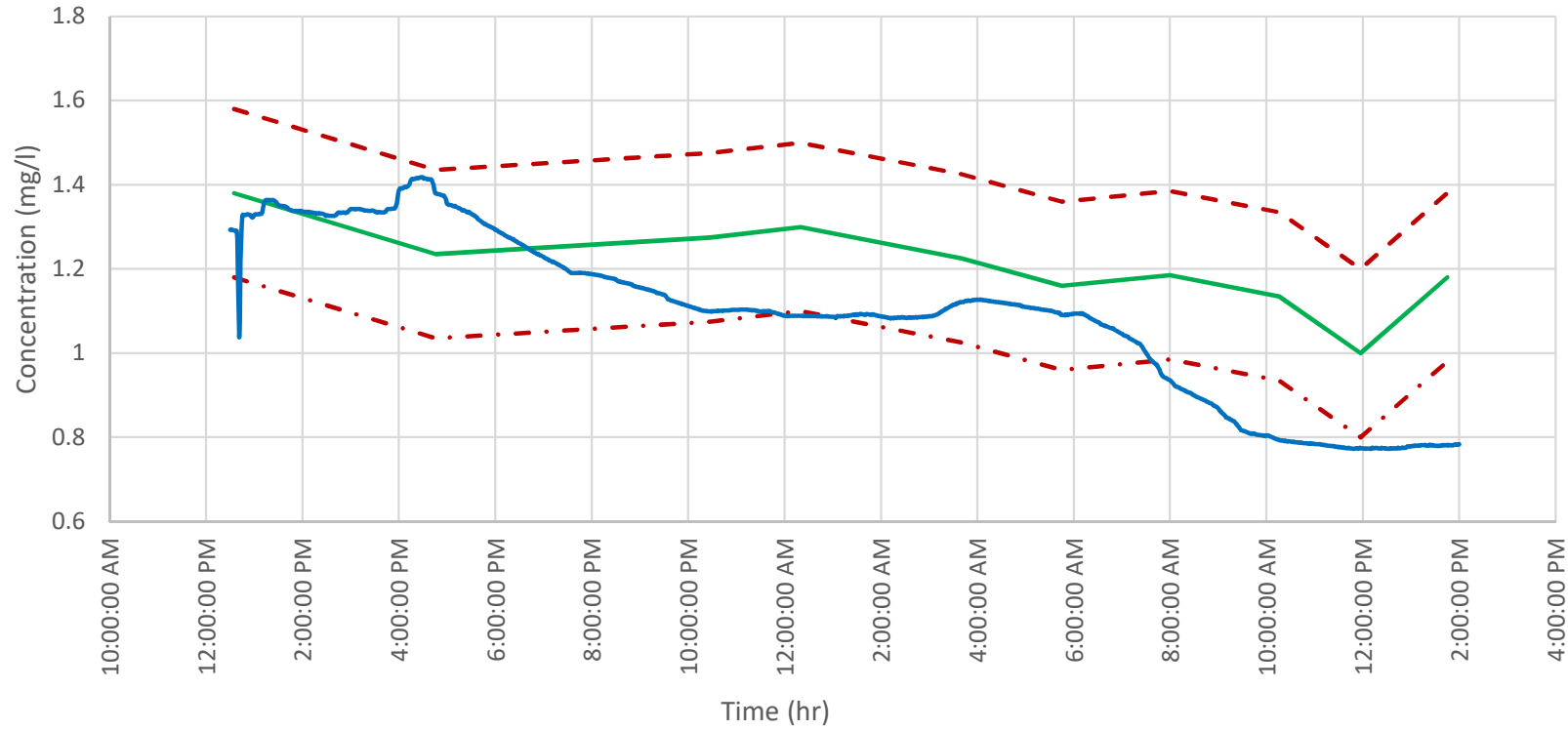

— Measured Concentration (mg/l) - - - Upper Band (mg/l) - . - Lower Band (mg/l) — Modelled Concentration (mg/l)

18855 Centre St Water Quality Validation

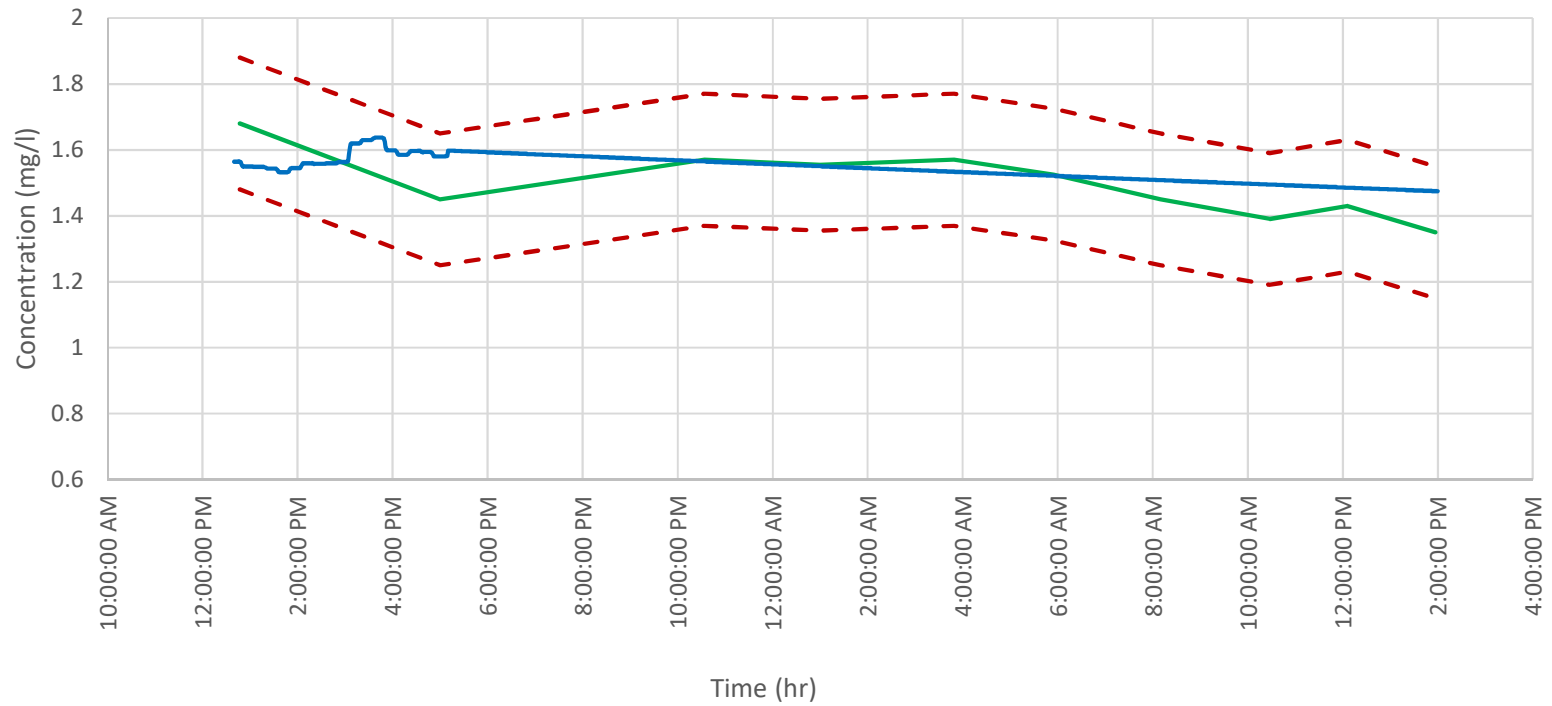

— Measured Concentration (mg/l) - - - Upper Band (mg/l) - - - Lower Band (mg/l) — Modelled Concentration (mg/l)

19178 9th Line Water Quality Validation

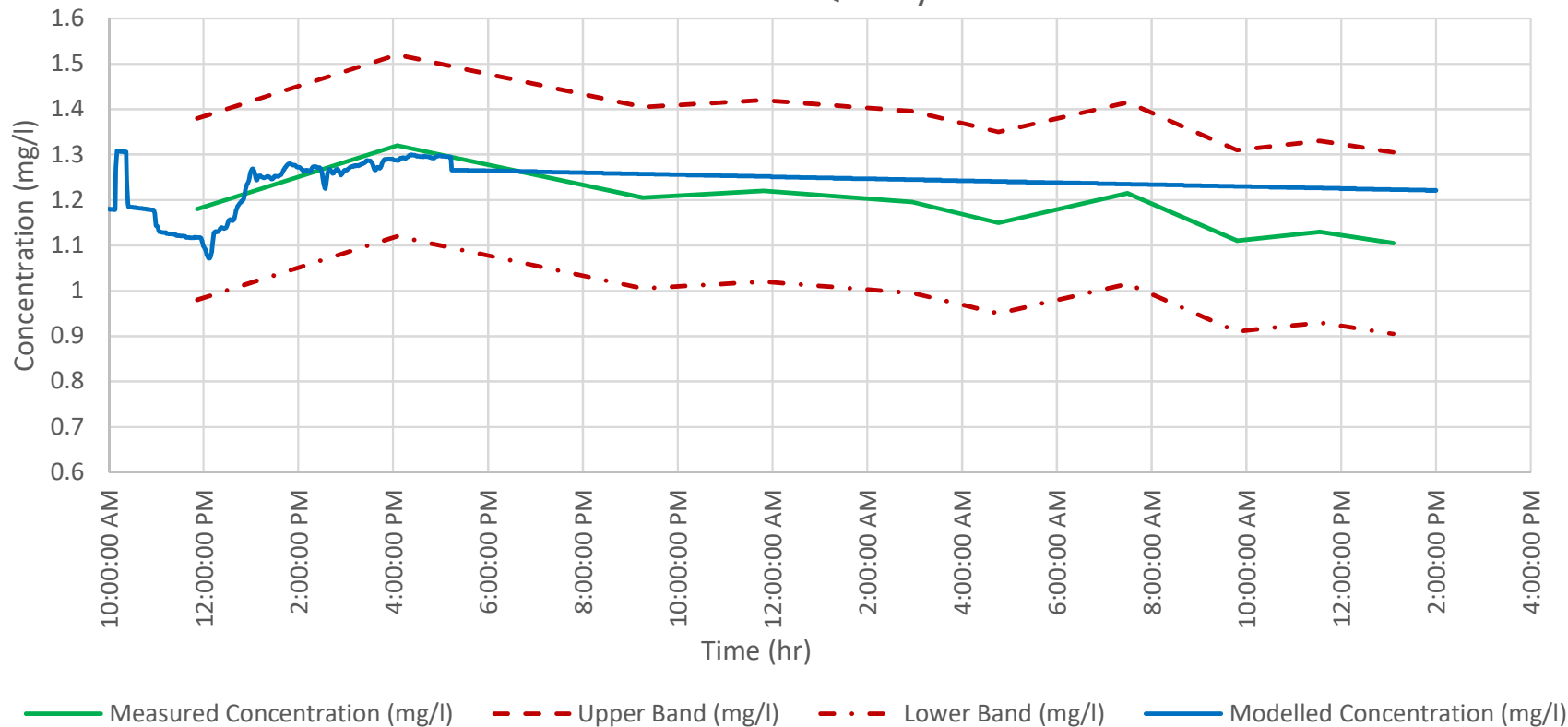

Appendix E

Hydraulic Model Results – Baseline Conditions

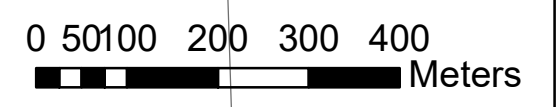
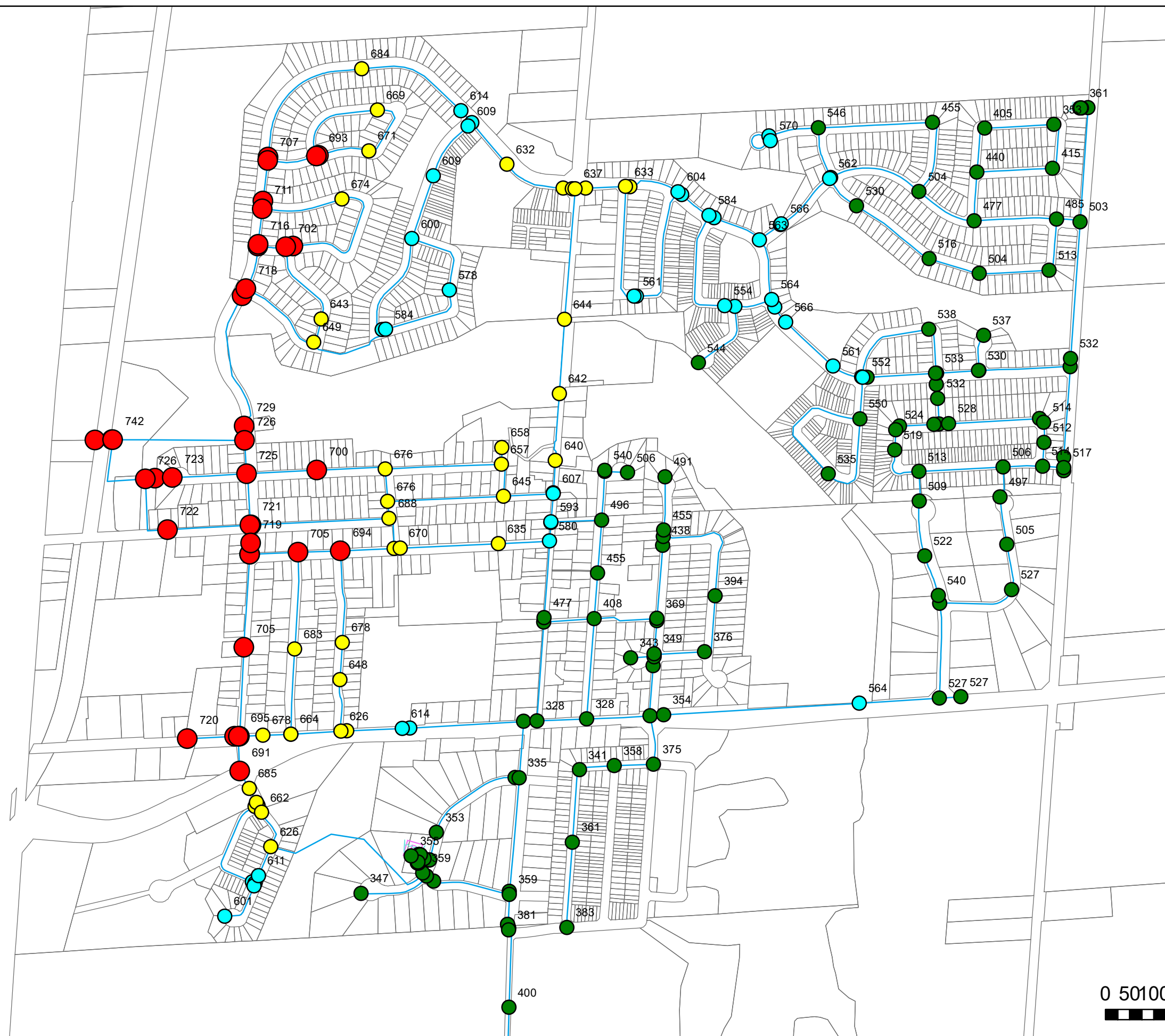
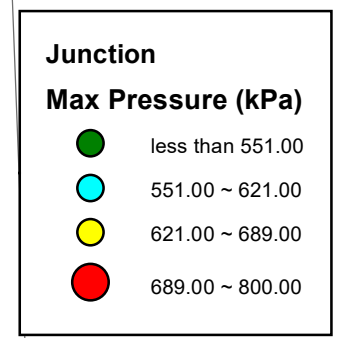

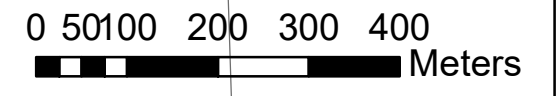
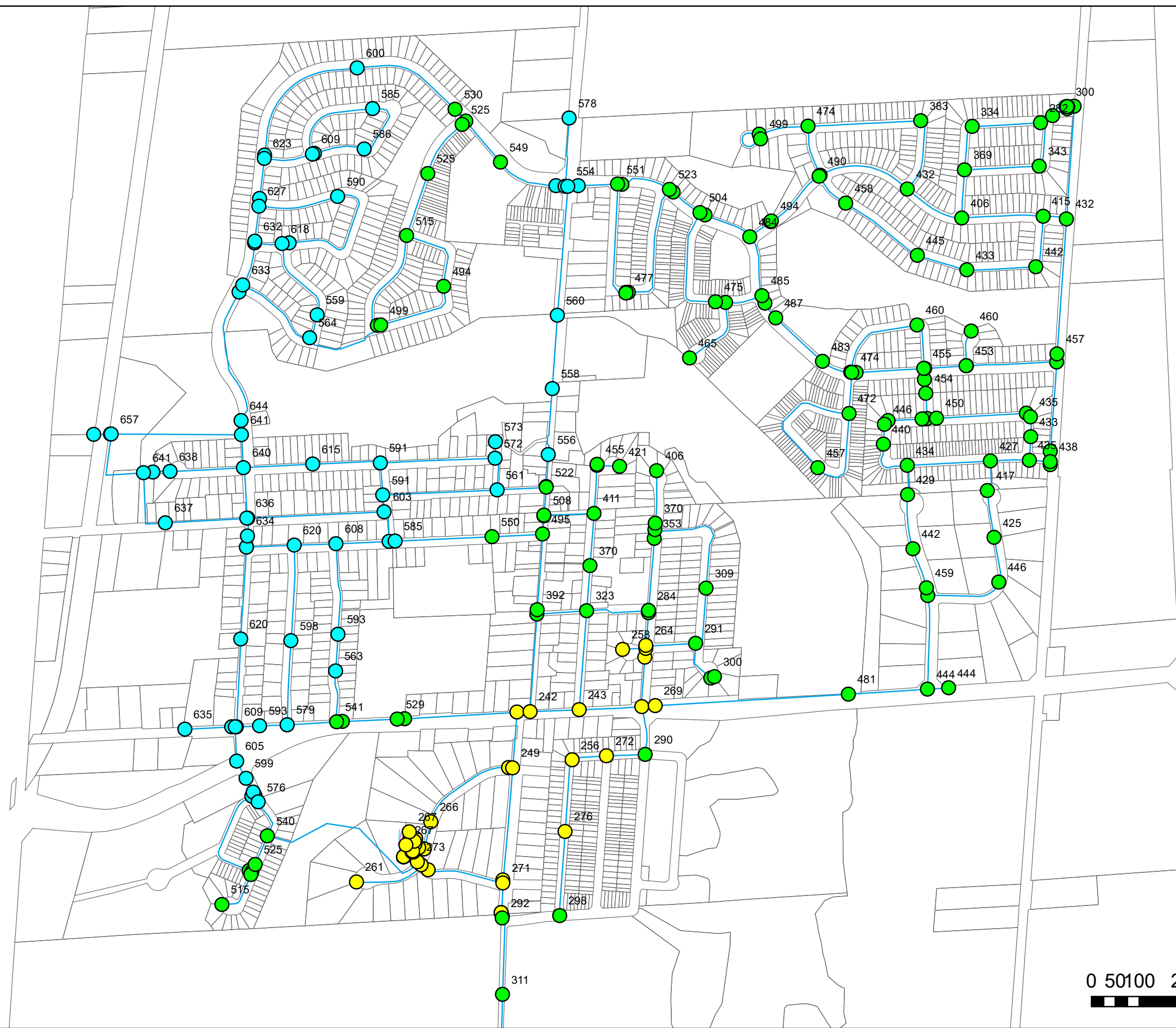
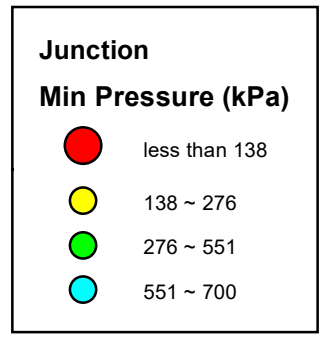

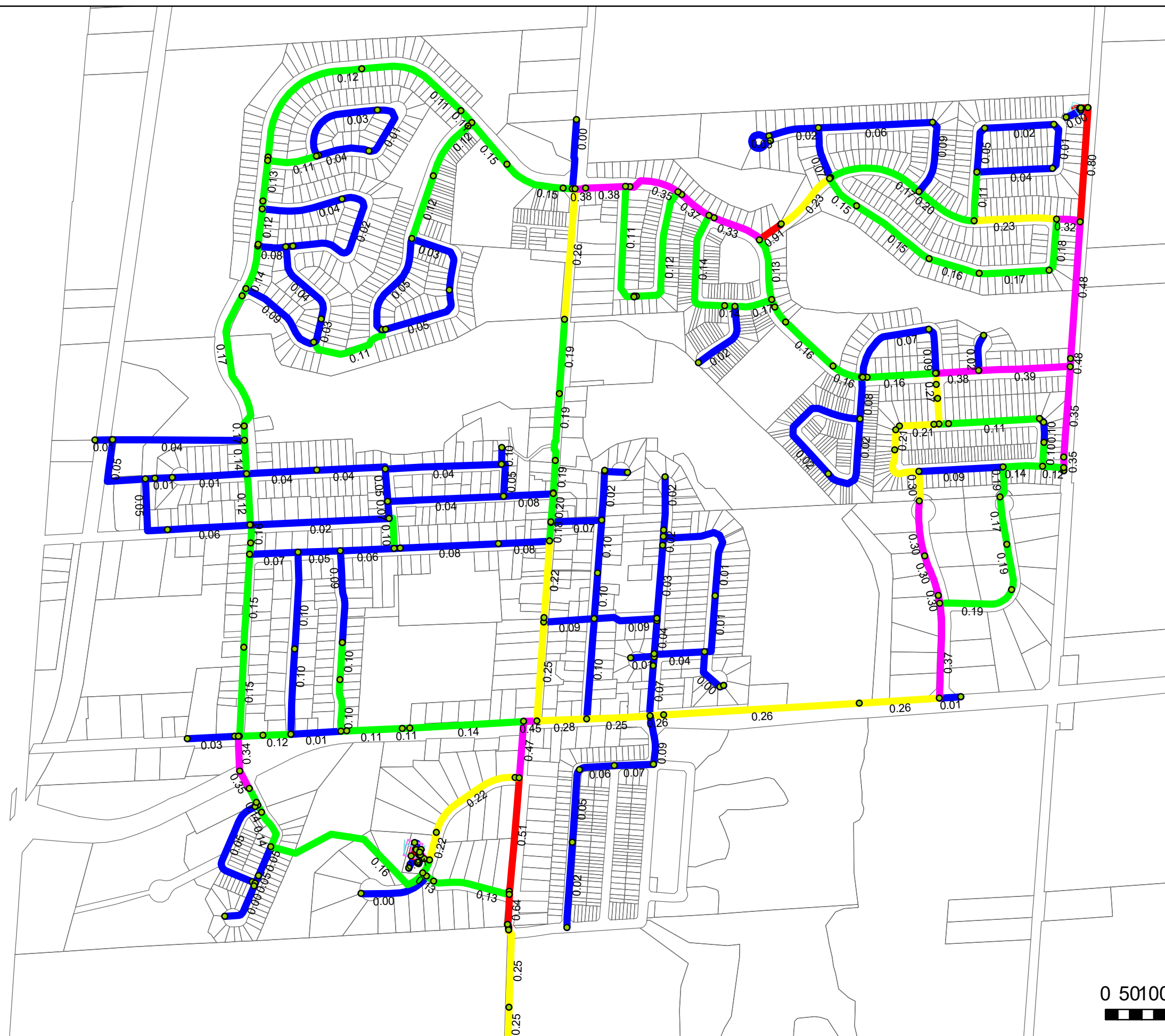

Pipe
Max Velocity (m/s)

- █ less than 0.1000
- █ 0.1000 ~ 0.2000
- █ 0.2000 ~ 0.3000
- █ 0.3000 ~ 0.5000
- █ 0.5000 ~ 1.0000

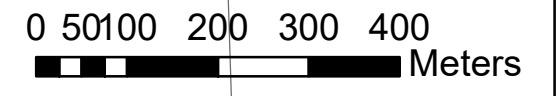

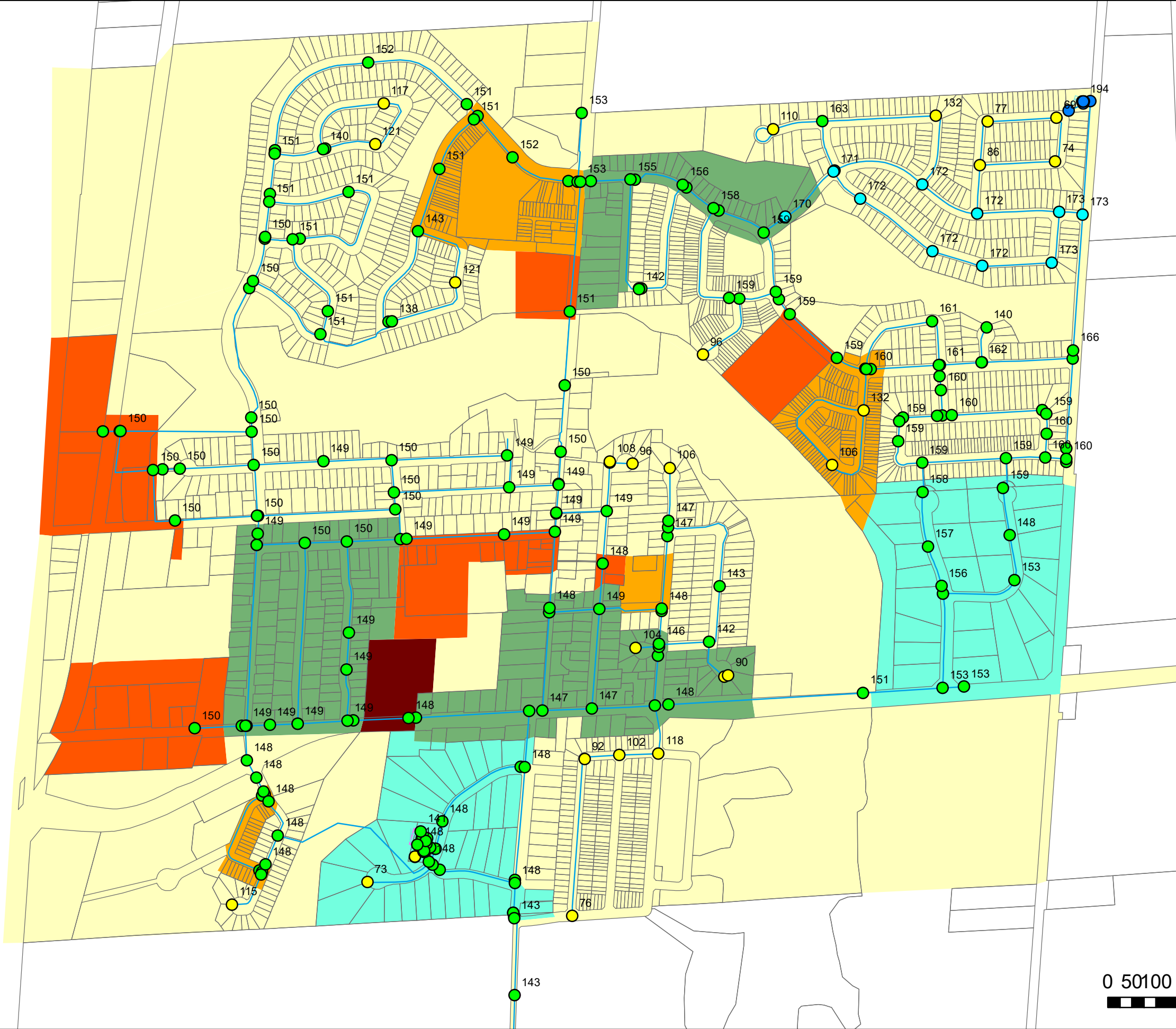

Junction Available Fire Flow (lps)

- less than 50
- 50 ~ 67
- 67 ~ 133
- 133 ~ 167
- 167 ~ 183
- 183 ~ 300

Fire Flow Targets (lps)

- 50 lps
- 67 lps
- 133 lps
- 167 lps
- 183 lps
- 250 lps

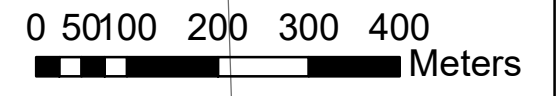

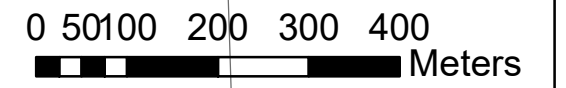
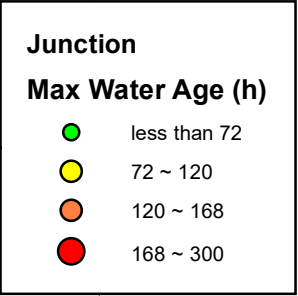
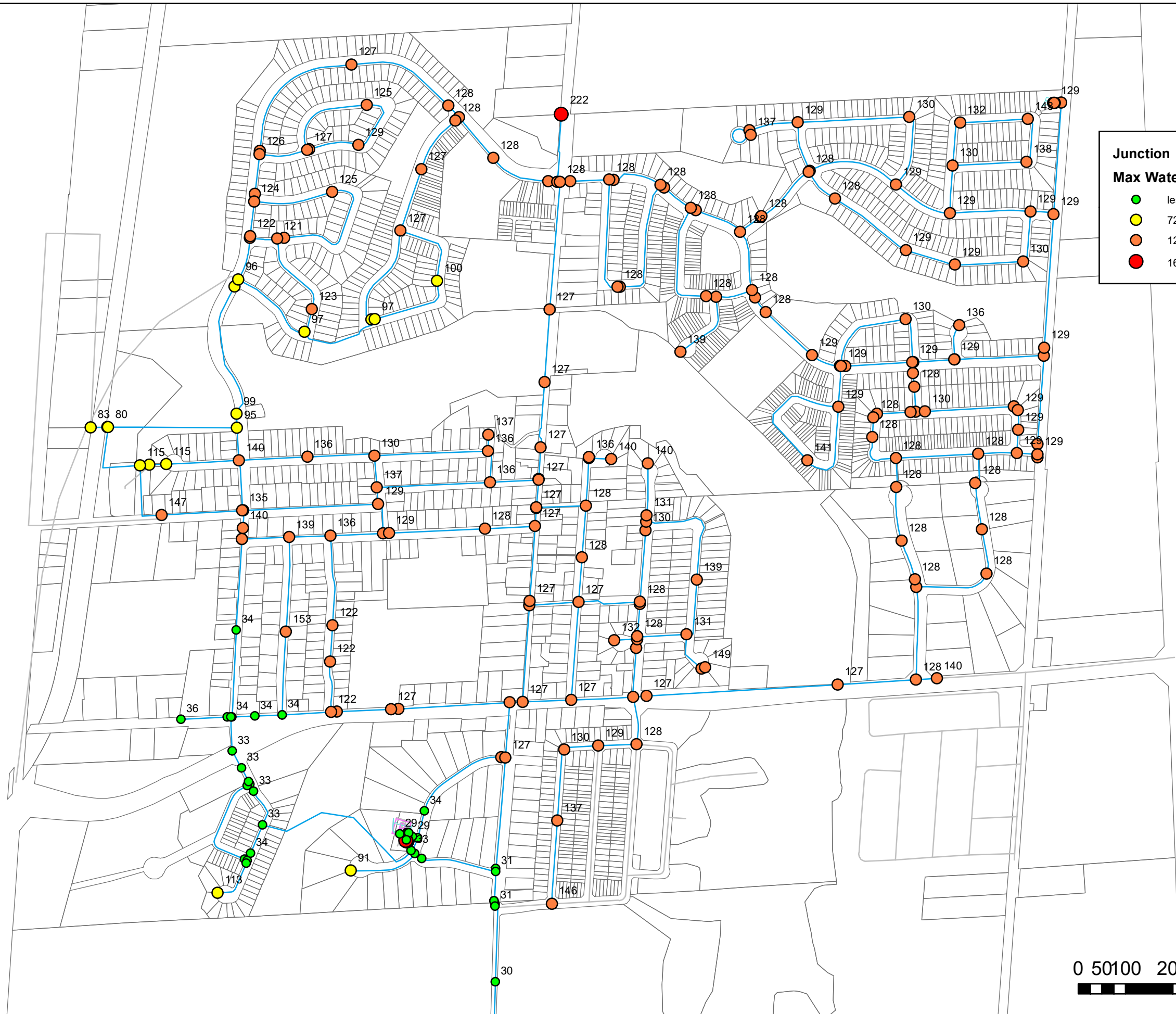

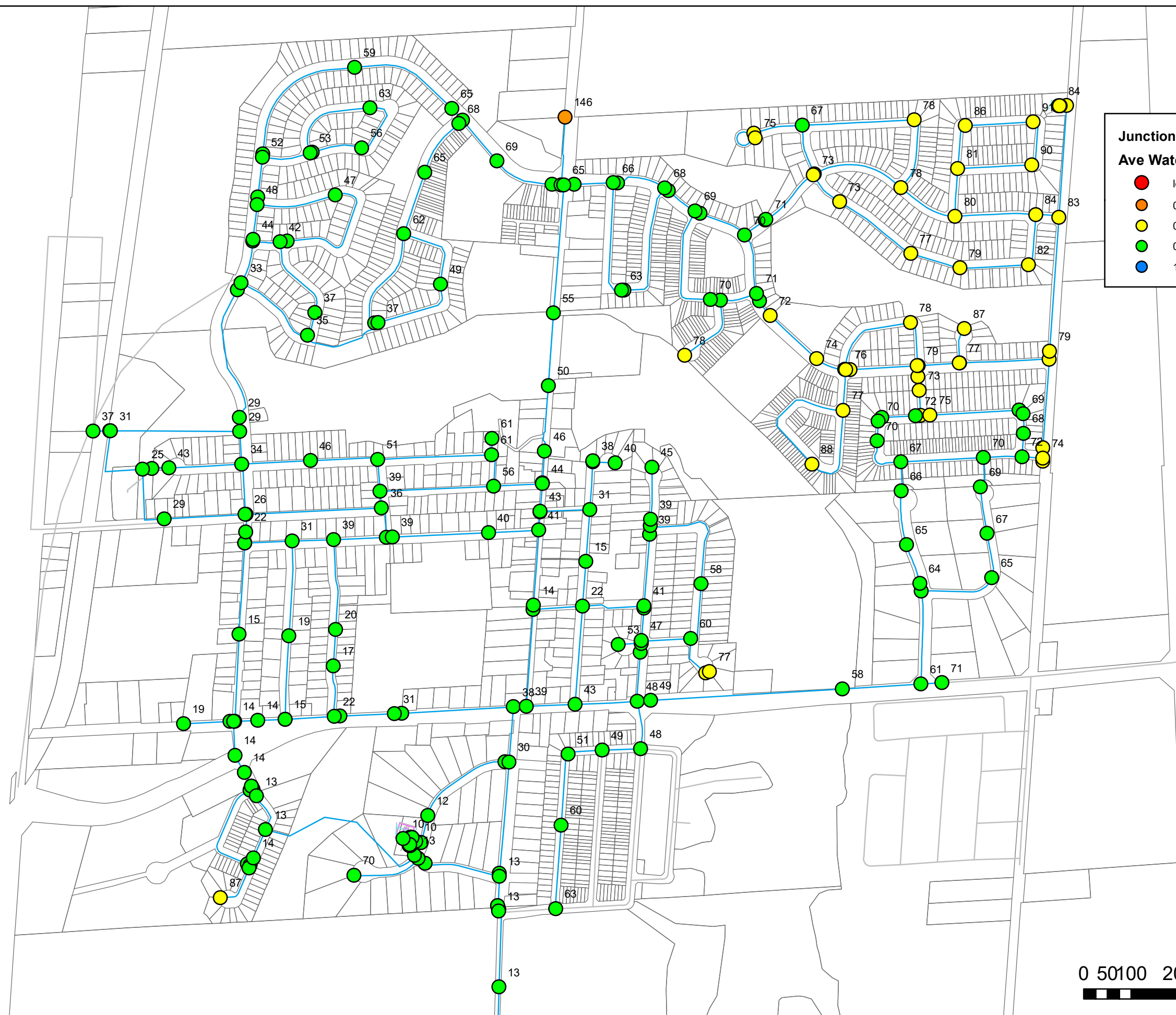

Junction
Ave Water Age (h)

- less than 0.10
- 0.10 ~ 0.40
- 0.40 ~ 0.50
- 0.50 ~ 1.00
- 1.00 ~ 2.00

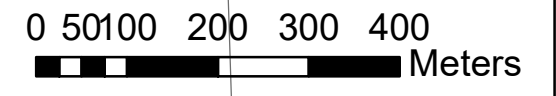

2016 ADD Tank Water Age

Average Age:
113 hours
Maximum Age:
129 hours

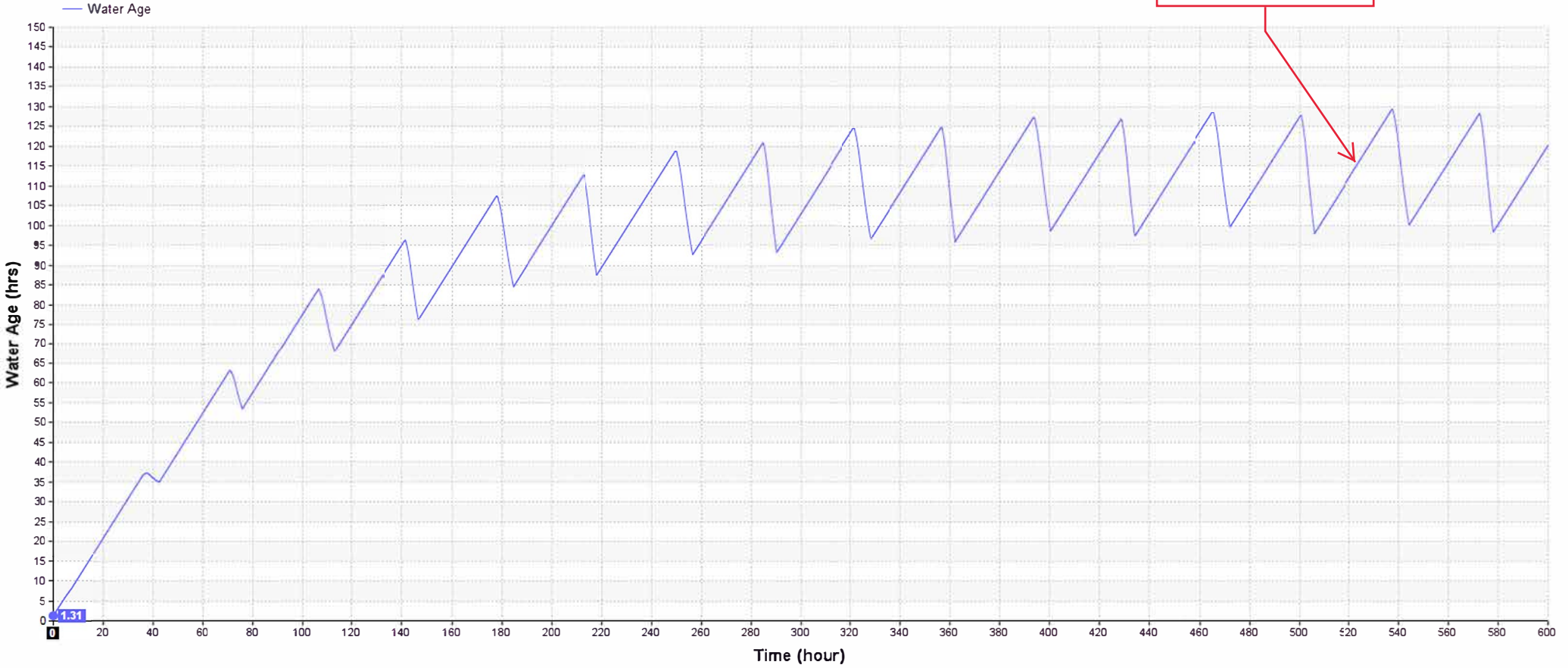

2016 MDD Tank Water Age

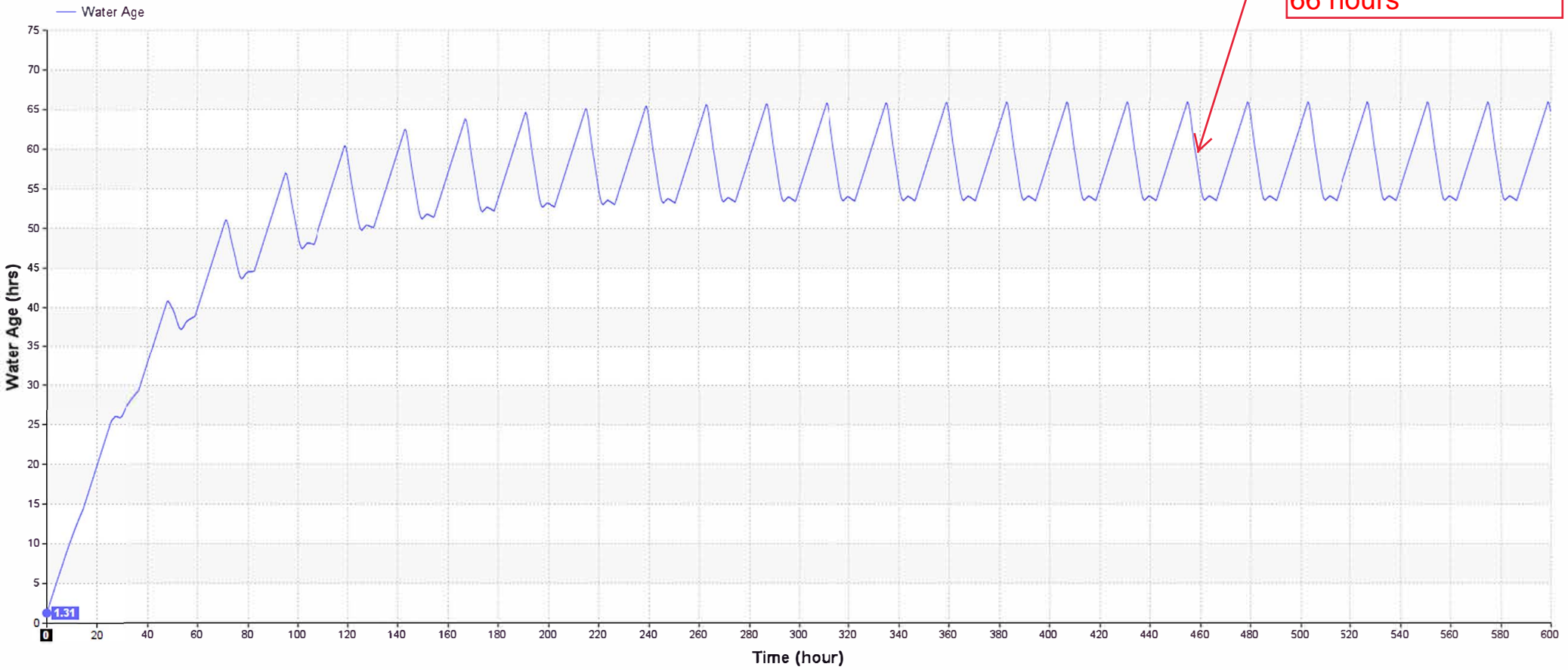

Average Age:
60 hours
Maximum Age:
66 hours

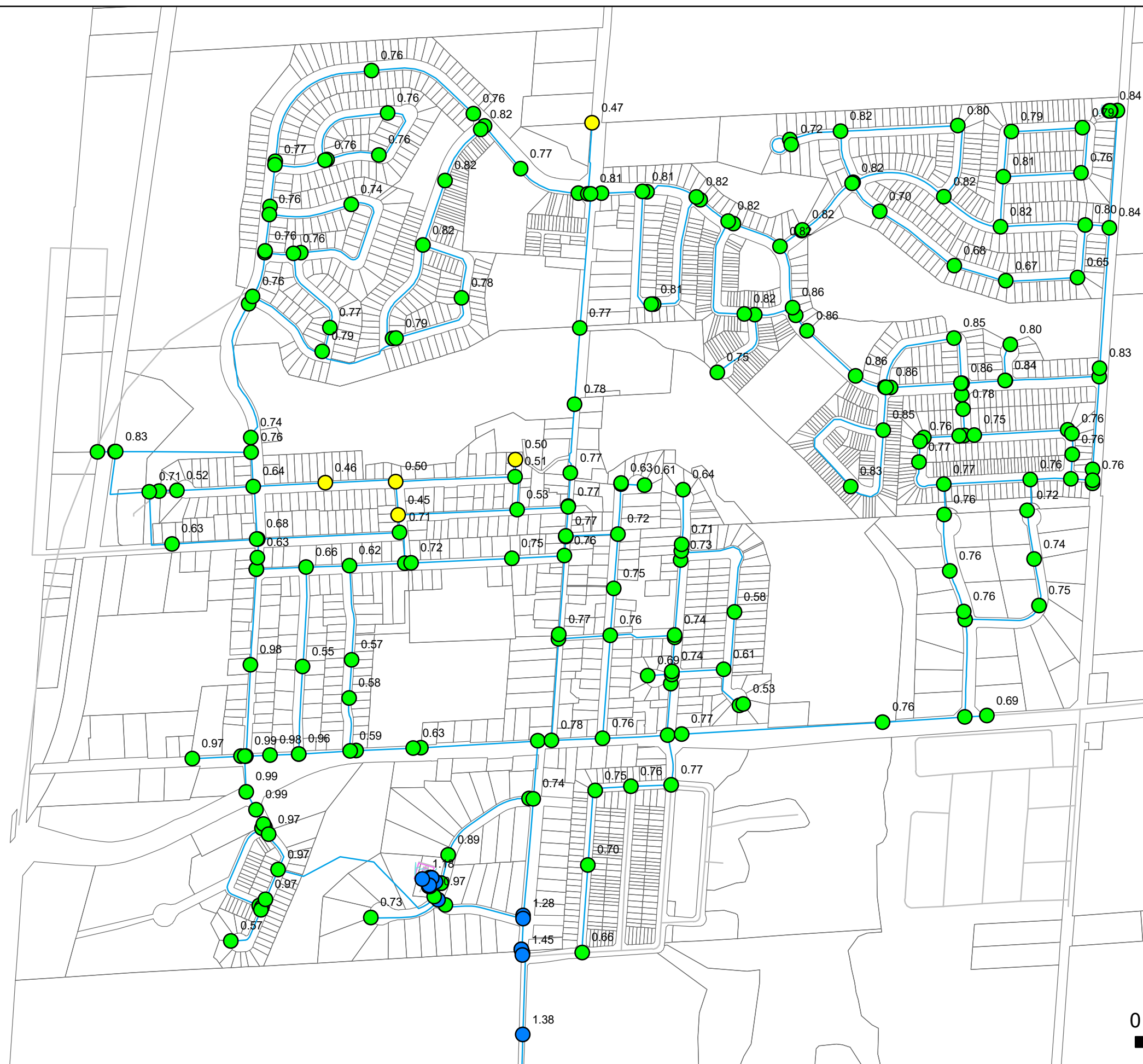

Junction	
Min Chlorine Residual (mg/l)	
●	less than 0.100
●	0.100 ~ 0.400
●	0.400 ~ 0.500
●	0.500 ~ 1.000
●	1.000 ~ 2.000

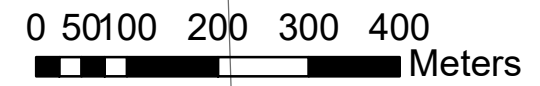

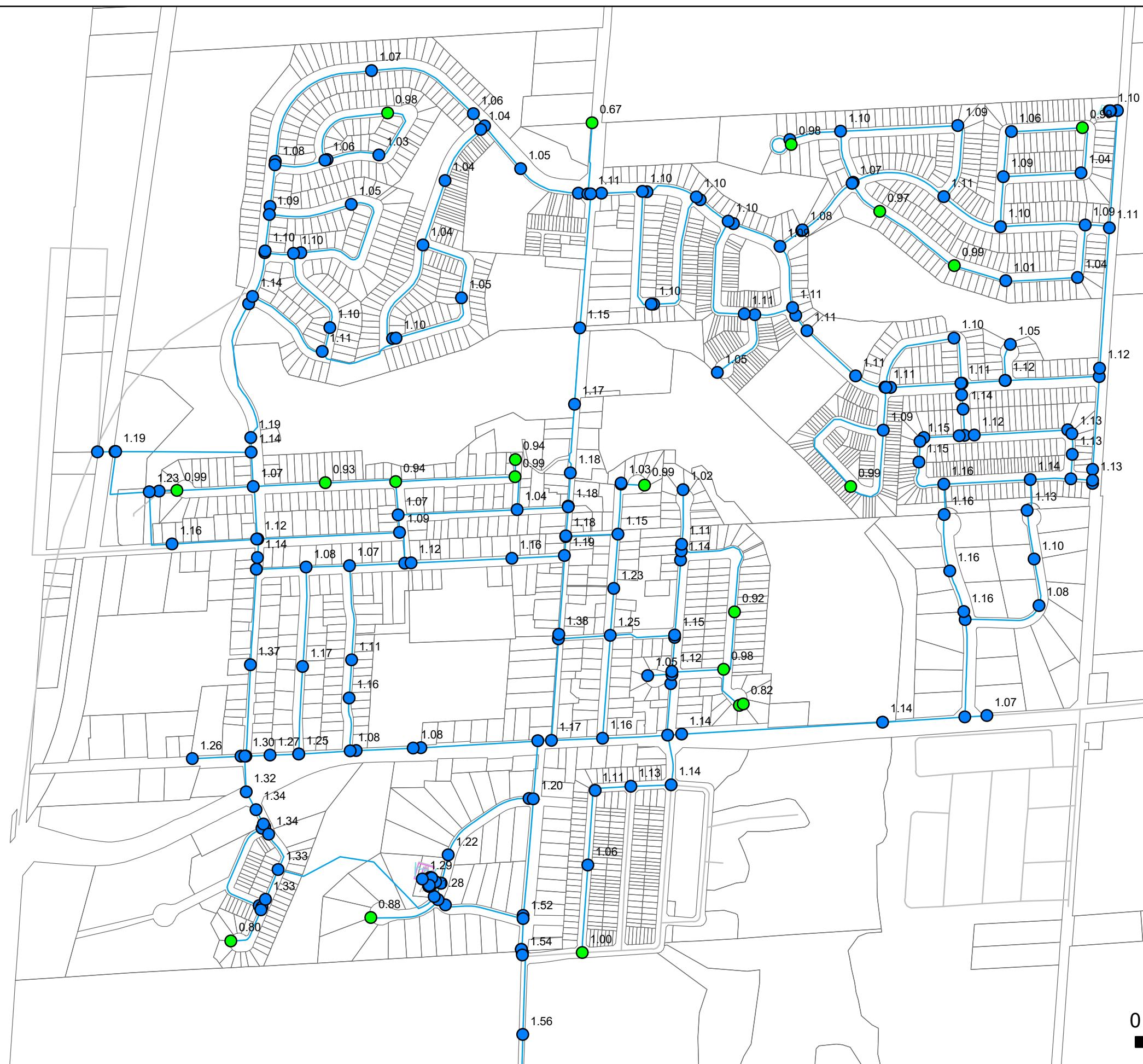

Junction
Ave Chlorine Residual (mg/l)

- less than 0.10
- 0.10 ~ 0.40
- 0.40 ~ 0.50
- 0.50 ~ 1.00
- 1.00 ~ 2.00

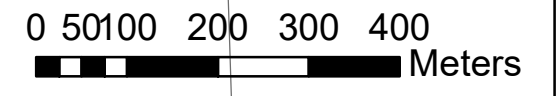

Appendix F

Mount Albert Distribution System Iron and Manganese Sampling Results

Mount Albert Water Supply Upgrades Class Environmental Assessment

Project No: CE731500
Document Title: Mount Albert Distribution System Iron and Manganese Sampling Results
Revision: Final Draft
Date: March 03, 2020
File Name: 20200303_FeMn_RsItsAppndx_r3.docx

Document history and status

Revision	Date	Description	Author	Checked	Reviewed	Approved
Draft1	2019/0927	Draft 1 Submitted for Review	M. Spanjers	S. Latorre	A. Yahoda	A. Yahoda
Draft 2	2019/12/12	Draft 2 Submitted for Review	M. Spanjers	S. Latorre	L. Jones	L. Jones
Final Draft	2020/03/03	Final Draft	M. Spanjers	M. Pellegrino	L. Jones	L. Jones

1. Introduction

As part of the Mount Albert Water Supply System Upgrades project, data on turbidity, iron (Fe) and manganese (Mn) within the distribution system was collected to develop an understanding of the total and dissolved iron and manganese levels in the distribution system under existing conditions and to evaluate whether sequestration is currently maintaining iron and manganese in the dissolved form throughout the distribution system.

2. Method and Materials

The testing followed the water quality sampling plan as attached (Attachment 1). The iron and manganese sampling plan was based on collecting 4 rounds of iron and manganese samples at 8 locations throughout the distribution system, the first round of samples collected while the well pumps were in operation (fill cycle) and the remaining three sampling rounds while the well pumps were not in operation (drain cycle). The sample station locations are detailed in Table 2-1 and Figure 2-1. In addition to the 8 distribution system sampling locations identified in the sampling plan, samples were also collected at each operating well. Additional details regarding the iron and manganese sampling approach are available in the full sampling plan (Attachment 1).

Table 2-1. Distribution Sample Locations

Sample Station Number	Address	Type
1	126 Mainprize Crescent	Exterior Sampling Station
2	19451 Centre St	Exterior Sampling Station
3	405 King St E	Exterior Sampling Station
4	74 Manor Glen Crescent	Exterior Sampling Station
5	Millennium Park at King St and Albert St	Exterior Sampling Station
6	5517 Mt Albert Rd	Exterior Sampling Station
7	18855 Centre St	Exterior Sampling Station
8	19178 Ninth Line	Elevated Tank

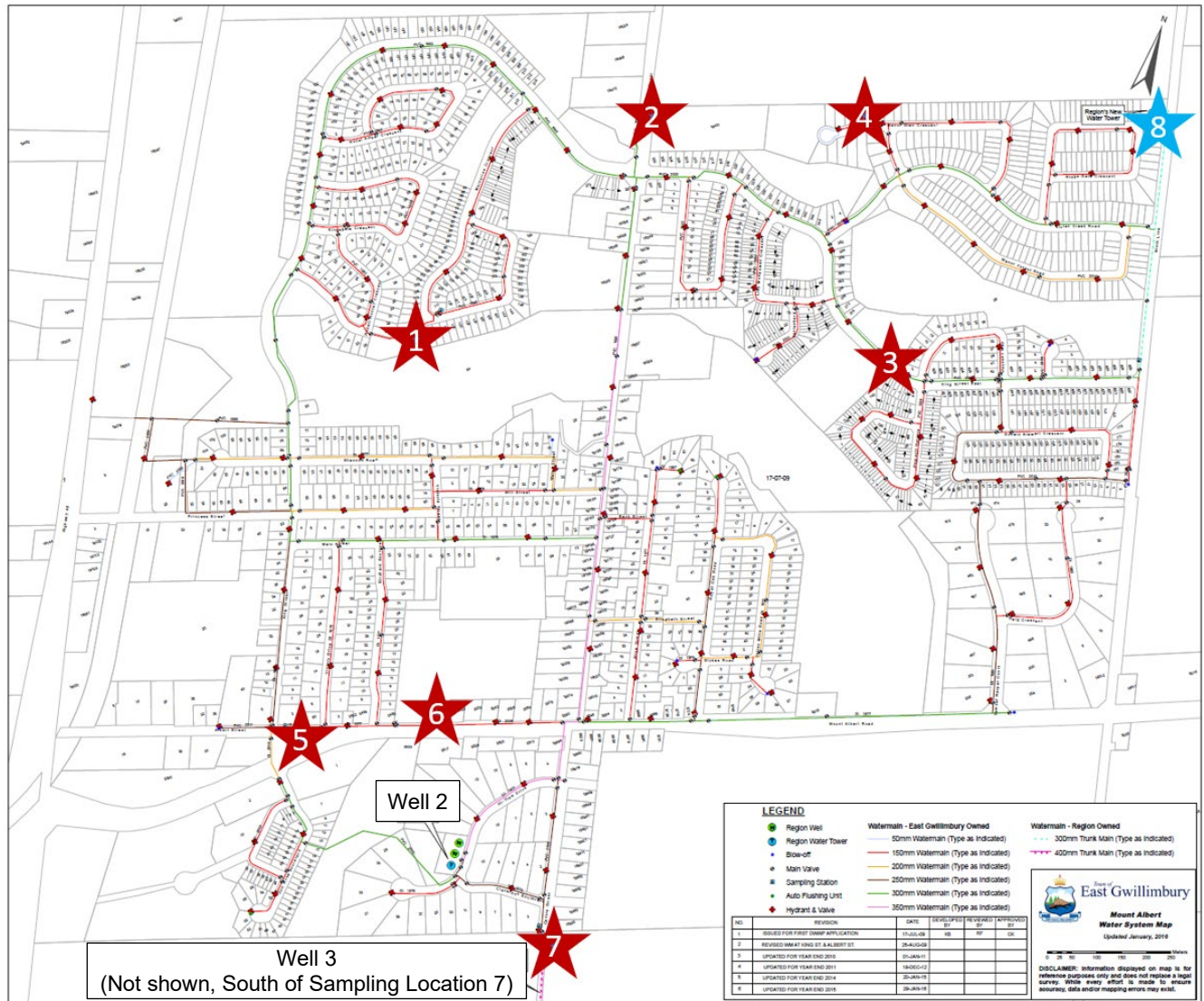

Figure 2-1 Distribution System Sample Locations

Red = Existing Sampling station, Blue = elevated tank

A site meeting was held at the Wells 1&2 Facility in Mount Albert at 8:00 AM on August 1, 2019, to commence the sampling project. At 9:12 AM, Well 2 and Well 3 started operating so that the Ninth Line Elevated Tank (hereafter referred to as “the elevated tank”) could begin filling. At 9:12 AM, the elevated tank was 59% full. At 9:34 AM a blockage in the sodium silicate dosing system was observed at the Well 2 site and YR staff switched to the standby sodium silicate pump to allow silicate addition to continue there.

The well sampling was collected at the following times:

- Samples were collected at 1:10 PM for Well 3
- Samples were collected at 1:50 PM at Well 2.

The distribution system sampling followed the follow timeframes:

- Wells pumps put into operation 9:12 AM, August 1, 2019 (Start of fill cycle)
- Round 1 began at 2:40 PM (pumps in operation), August 1, 2019
- Pumps turned off at 5:20 PM, August 1, 2019 (end of fill cycle, start of drain cycle, tower level 90.4%)

- Round 2 began at 7:00 PM, August 1, 2019 (tower level 85.9%)
- Round 3 began at 6:20 AM, August 2, 2019 (tower level 68.0%)
- Round 4 began at 3:50 PM, August 2, 2019 (tower level 49%)

It is noted that the first three sampling rounds were collected in parallel with the water quality sampling performed to support the development of the water quality model. A fourth-round of sampling was undertaken after the water quality model sampling was complete, where only iron and manganese were analyzed.

Iron and manganese sampling used 120 mL plastic sample bottles, pretreated with 1 mL of nitric acid. For total metal analyses, samples were collected directly in sample bottles from the tap at each sample station and analyzed at AGAT Labs for total iron, manganese and silicon using inductively coupled plasma mass spectrometry (ICP-MS). To obtain dissolved metal data, 60 mL of sample was poured directly into a 60 mL syringe (to minimize the opportunity for iron oxidation) and immediately filtered using filter paper (Foxy Life Sciences EZflow membrane disc filter, Nylon, 25 mm dia, 0.45 µm pore size, PN 364-3212-OEM), mounted in a 25 mm filter holder (Pall "Easy Pressure Syringe Filter Holder", PN B00N3ZSHZE), into the same type of 120 mL sample bottle used for total metal analyses.

As quality control measures, replicate (duplicate or triplicate) samples were taken and field blanks were prepared and sent for metals analysis at AGAT labs. Replicate samples were taken at two locations for each sampling event. Field blanks for total metals analysis were created by filling a sampling bottle directly with distilled water. Field blanks for dissolved metals were created by rinsing the sampling syringe three times with distilled water, rinsing the filter holder with distilled water, and filtering 60 mL of distilled water through a new filter paper directly into a sampling bottle. Field blanks were created during Round 1 and Round 4. AGAT labs also conducted a quality assurance program where duplicates, method blanks, a reference standard, a method blank spike, and a spiked sample were analyzed for select samples.

Chlorine analyses were obtained using a Hach SL1000 handheld meter and chemkeys for free and total chlorine. pH, dissolved oxygen and temperature data were obtained using a YSI 600 XLM MP sonde with a flow-through cell.

3. Results and Discussion

Total and dissolved iron and manganese data and silicon data are available for all four rounds of sampling with turbidity, chlorine (free and total), pH, and dissolved oxygen (DO) data available for the rounds 1-3 as noted previously, as Attachment 2. The ICP-MS data from the lab reported concentrations as silicon (Si); however, silicon data is represented in units of mg/L-SiO₂ in this appendix. To convert data from silicon to SiO₂, the data was adjusted based on SiO₂ being made up of 46.8% silicon by weight.

Pictures of the cataloged filter papers used to filter the samples are included as Attachment 3 to support the discussion of results. Trends for iron concentration and proportion of metal in the dissolved form are provided for each sampling station as Attachment 4. The discussion of results herein has been divided into the following subsections:

- Quality Control Results
- Well Sampling Results
- Dissolved Oxygen Results
- Fill Cycle Sampling Results (Round 1)
- Drain Cycle Sampling Results (Rounds 2, 3, and 4)

3.1 Quality Control Results

3.1.1 Lab Quality Assurance Program

Key results and findings from the lab quality assurance program are detailed to provide context for the accuracy of measurement data and the resulting interpretation. Table 3-1 provides a summary of the findings with Data from analyses included in Attachment 5.

Table 3-1. Summary of Lab Quality Assurance Results

Quality Check	Lab's Acceptable Limits (where noted)	Total Iron	Total Manganese	Total Silicon
Duplicate Analysis	-	Relative per cent difference ranged from 6.3% to 17.3%	Relative per cent difference ranged from 0.0% to 3.5 %	Relative per cent difference ranged from 3.6% to 13.7%.
Method Blank	-	Measured concentration was less than method detection limit (<0.010 mg/L)	Measured concentration was less than method detection limit (<0.002 mg/L)	Measured concentration was less than method detection limit (<0.05 mg/L)
Reference Standard Analysis	90-110%	Recovery ranged from 94% to 108%	Recovery ranged from, 103% to 109%	Recovery ranged from 97% to 107%
Method Blank Spike	90-110%	Recovery ranged from 99% to 110%	Recovery ranged from, 102% to 110%	Recovery ranged from 95% to 109%
Sample Matrix Spike	70-130%	Recovery ranged from 92% to 116%	Recovery ranged from, 99% to 107%	Recovery ranged from 71% to 100%

The duplicate analysis suggested that there was greater variability in the iron and silicon analyses than for manganese given the larger relative percent difference. The method blank came back as less than the method detection limit, as would be expected. The results from the reference standard analysis, method blank spike, and sample matrix spike all were within the lab's noted acceptable limits.

3.1.2 Field Blanks

Distilled water was processed on-site through the sampling and filtration procedure as a field blanks. Measured manganese and silicon concentrations were below the respective method detection limits of 0.002 and 0.05 mg/L for all field blanks. Measured iron concentrations for the field blanks are shown in Figure 3-1.

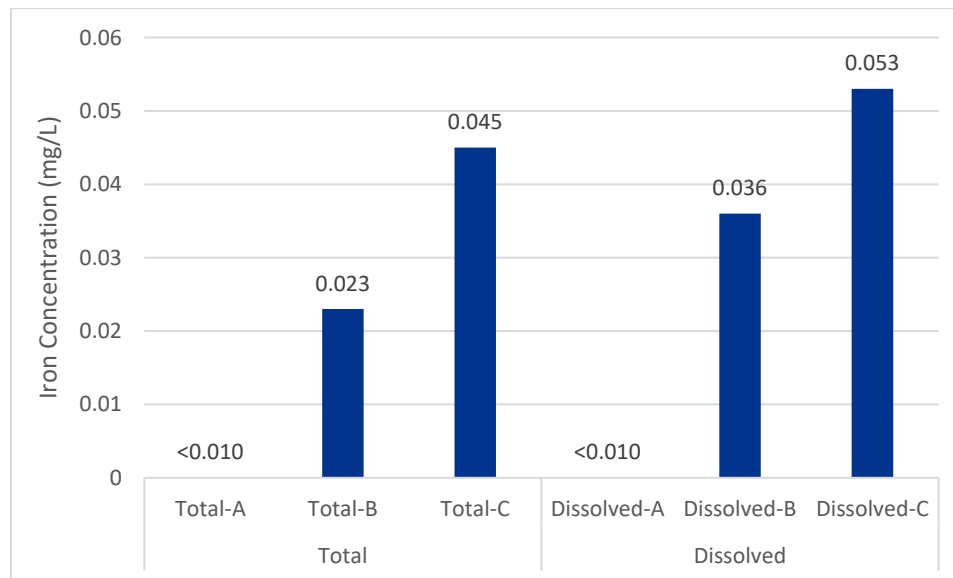

Figure 3-1. Iron Concentrations Measured in Field Blanks

Iron field blanks Total-B, Total-C, Dissolved-B, and Dissolved-C all had iron concentrations greater than the method detection limit indicating that there was a low level of iron concentration in the blanks. It can also be noted that

- There was no iron in the Total-A and Dissolved-A field blank indicating that there was initially no iron in the distilled water
- The level of contamination appears to have increased between the B and C sets of field blanks
- The dissolved iron concentrations are higher than the total iron concentrations
- There was iron contamination but no manganese or silicon contamination.

As all of the method blanks analyzed at the lab and the A set of field blanks had no iron present, it is considered unlikely that the iron measurements were due to an analytical error.

It was considered whether the bulk distilled water or blank samples could have been contaminated, for example by spray from the distribution system sampling taps or cross-contamination during filtration. However, contamination from spray from sampling ports is unlikely given that the blanks were processed at a distance from the sampling ports and there was also no evidence of silicon or manganese contamination which would have been present in the spray. Cross-contamination during filtration was also considered unlikely given that the syringe and filter holder were rinsed and residual iron in the syringe or filter holder from previous analyses would be expected to wash out between B and C blank sets.

While there is no apparent source that can be attributed to the iron contamination; it is considered that the impact of the relatively low levels observed, compared to historical measurements of iron in the system, would not significantly alter the conclusions developed through the analysis reported herein.

3.1.3 Measurements on Replicate Samples

Figure 3-2, Figure 3-3, and Figure 3-4 show the results from the analysis of replicate samples. Manganese measurements among replicate samples were similar; however, there was a higher degree of variability among silicon and iron measurements. The difference between iron measurements on replicate samples ranged from 0 to 0.064 mg/L. The difference between silicon measurements on replicate samples ranged from 0 to 5.4 mg/L-SiO₂.

The variability between replicate samples for both silicon and iron replicate measurements were higher in several cases than would be expected based solely on the relative percent differences observed from the lab quality assurance program. The variability could reflect the changing conditions given that replicate samples were collected sequentially over a period of time from the sampling location or could reflect an impact from contamination as noted previously. As noted previously, this variability has been taken into account in the interpretation of results and subsequent conclusions.

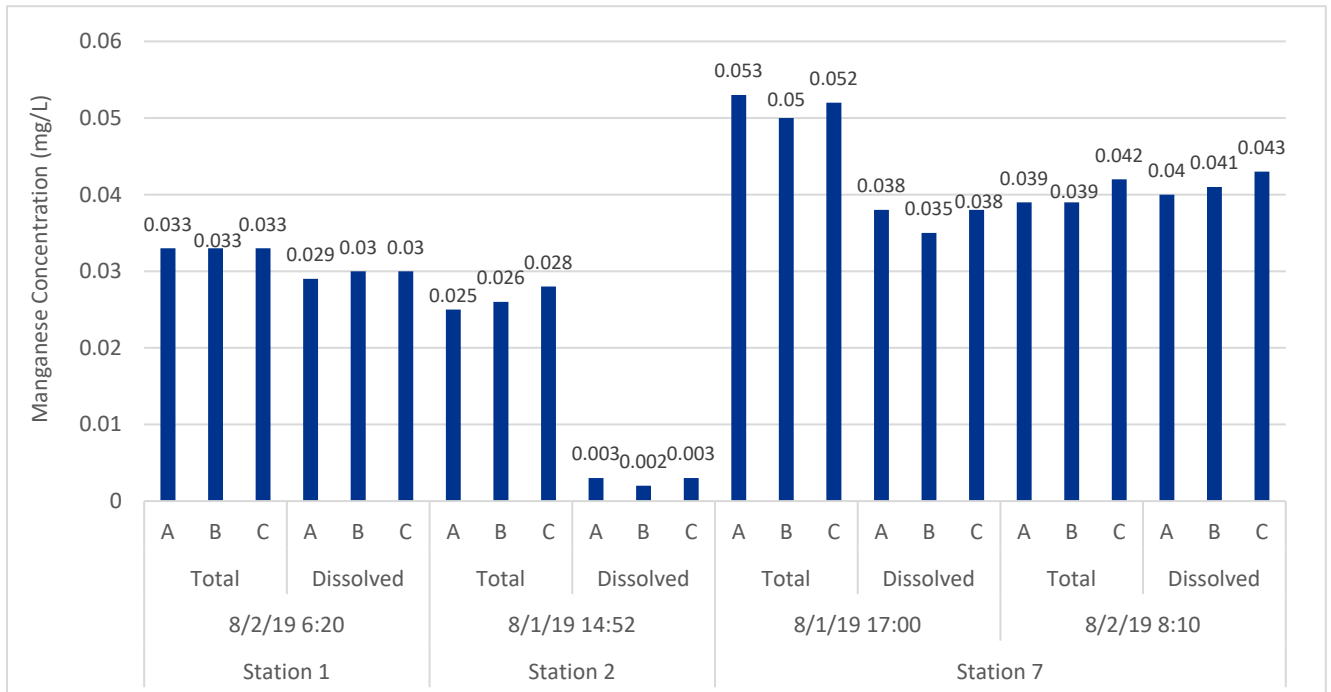

Figure 3-2. Manganese Concentrations Measured in Replicate Samples

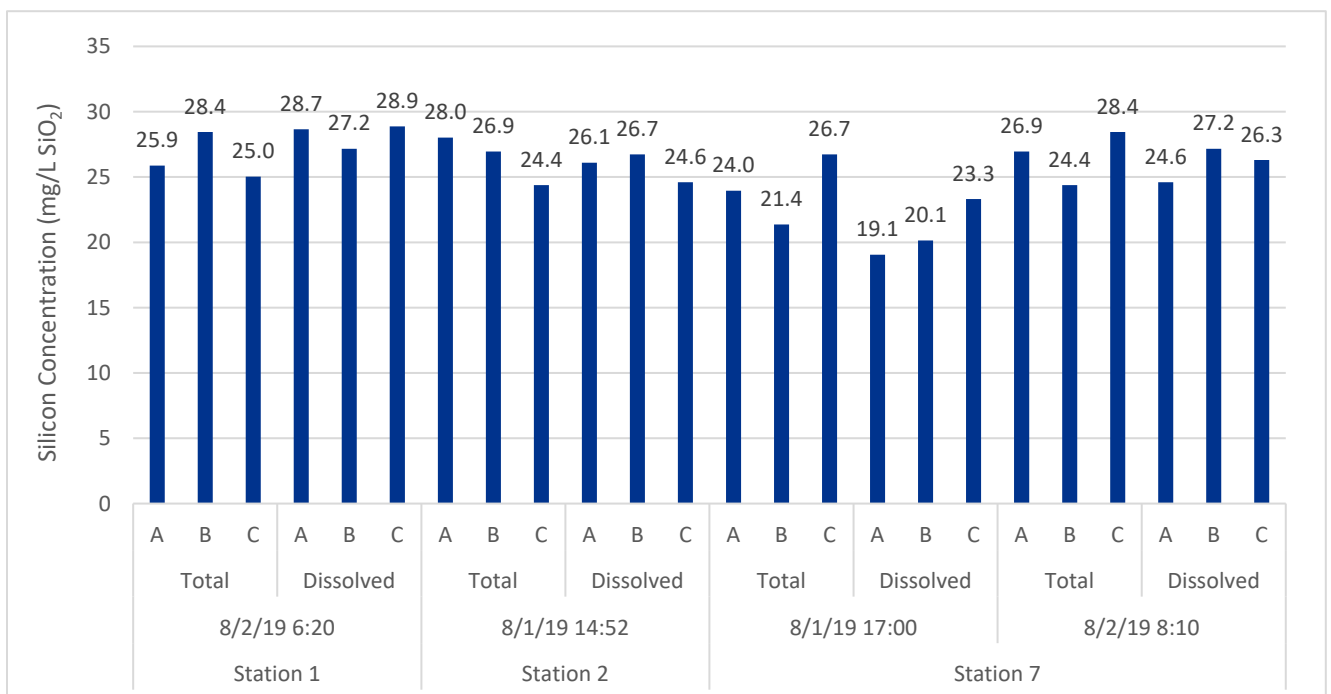

Figure 3-3. Silicon Concentrations Measured in Replicate Samples

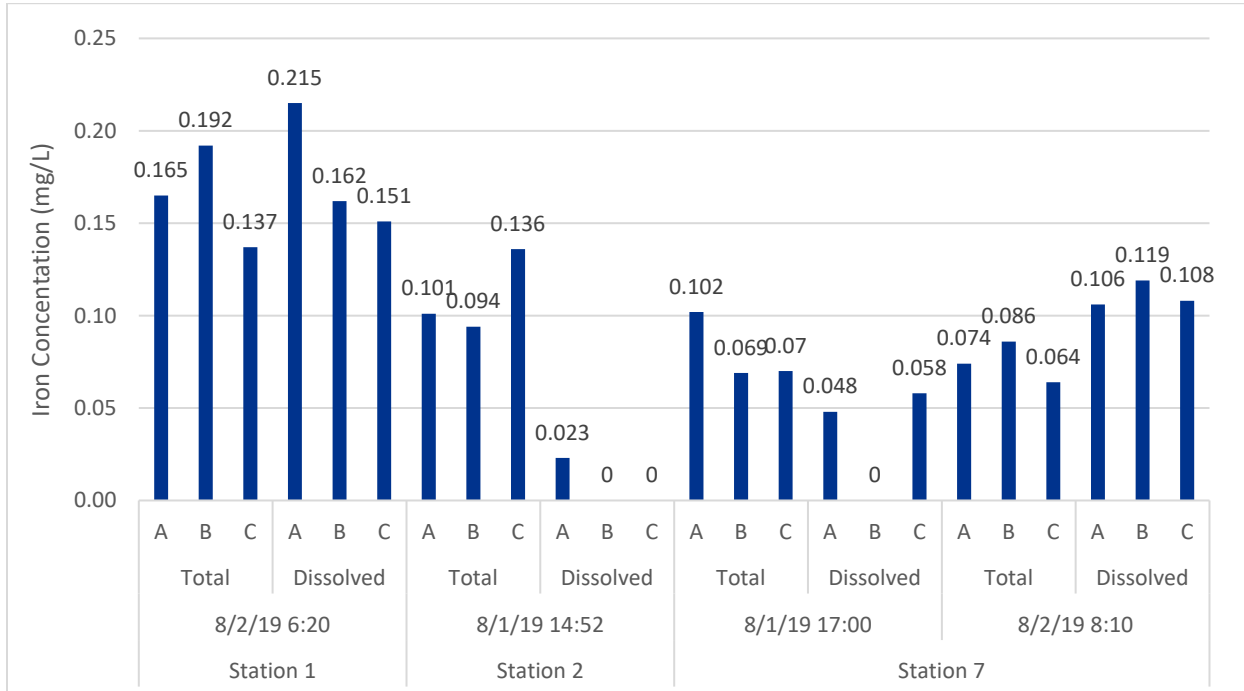

Figure 3-4. Iron Concentrations Measured in Replicate Samples

Note that where dissolved iron concentrations are not shown, the dissolved concentrations were below the method detection limit.

3.2 Dissolved Oxygen

The inlet pipe of the Ninth Line elevated tank terminates at an elevation of 312.790 m, as demonstrated in Figure 3-5. This results in a cascade effect when the tank is filling and the water level is below this elevation, aerating the water and increasing the dissolved oxygen concentrations of tank-supplied water. As the dissolved oxygen levels in the well supplies were low, analysis of dissolved oxygen at the sample stations compared to well and tank levels, provided an opportunity to assess whether water passed through the tank en-route to a sample station. This information can be used to aid in the interpretation of the iron and manganese sampling results.

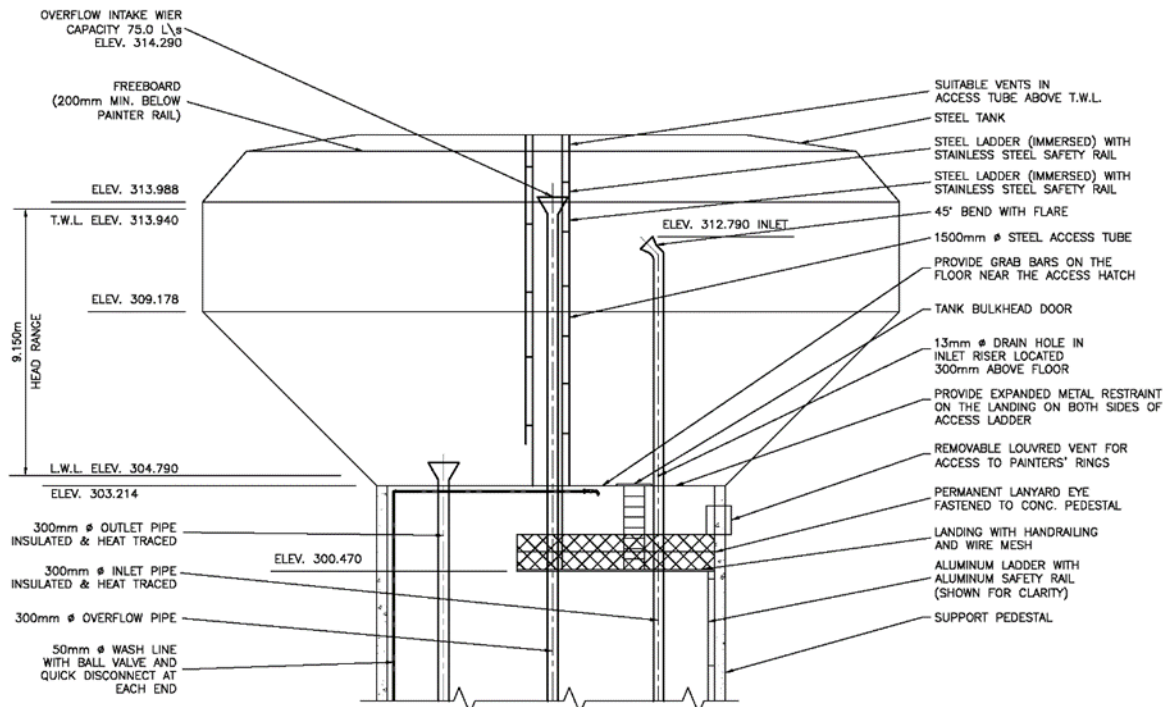

Figure 3-5. Schematic of Mount Albert Ninth Line Elevated Tank

Table 3-2 presents the observed dissolved oxygen concentrations.

Table 3-2. Dissolved Oxygen Concentration

Parameter	Location									
	Well 2	Well 3	1	2	3	4	5	6	7	8
Pipe Material	-	-	PVC	PVC	PVC	PVC	DI	DI	PVC/CP	-
Fill Cycle (Round 1) DO (mg/L)	0.47	0.5	0.37	4.68	0.5	2.53	0.72	0.4	0.32	0.95
Sampling Round 2 DO (mg/L)	-	-	0.37	4.47	5.52	4.41	1.91	4.87	0.39	5.60
Sampling Round 3 DO (mg/L)	-	-	0.54	4.01	5.20	5.60	0.60	0.44	0.47	5.88

Inspection of the data indicates that the wells and stations where supply is likely from the wells (e.g. station 7) had low dissolved oxygen concentration and water that exited the tank during the drain cycles had high oxygen concentrations, as would be expected. This supports the conclusion that water is aerated as it passes through the tank and that high dissolved oxygen concentrations can be used as an indicator that water supply has passed through the tank. The data, therefore also suggests that:

- Throughout the sampling period (Rounds 1-3), Station 2 demonstrated dissolved oxygen concentration indicative of supply that had passed through the tank

- During the drain cycle, Stations 3 and 4 dissolved oxygen concentration indicate supply from the tank
- During Round 2, Station 6 dissolved oxygen concentration suggest supply from the tank
- Station 4, during Round 1, and Station 5, during Round 2, may have been receiving some water that passed through the tank; however, this may have been water from a previous cycle or water that was mixed with well water that had not passed through the tank given that the dissolved oxygen concentration was lower than that observed at most other locations with elevated dissolved oxygen concentrations.

3.3 Well Sampling Results

Water samples were collected from Well 2 and Well 3 during the fill cycle to compare against historical values and drinking water standards and objectives and guidelines (Table 3-3).

Table 3-3. Comparison of Historical and Current Well Data

Parameter	Drinking Water Standards or Guidelines ⁽¹⁾	Historical (2010-2015) Raw (Average and Range)		Historical (2010-2015) Treated (Average and Range)		August 1, 2019 Treated	
		Well 2	Well 3	Well 2 ⁴	Well 3	Well 2	Well 3
Total Fe (mg/L) (min-max)	0.3 (AO)	0.421 (0.024-1.05)	0.093 (0.064-0.150)	NA	0.103 (0.066-0.160)	0.480	0.108
Total Mn (mg/L) (min-max)	0.05 (AO) HC: 0.12 (MAC) ² HC: 0.02 (AO) ³	0.055 (0.041-0.082)	0.054 (0.047-0.060)	NA	0.044 (0.038-0.051)	0.071	0.037
pH (Treated)	6.5-8.5 ⁵	7.97 (7.75-8.19)	7.83 (7.56-8.01)	NA	7.84 (7.65-8.10)	7.85	7.48

Notes:

1. Ontario Drinking Water Standards (ODWS) O.Reg. 169/03 - Maximum Acceptable Concentration (MAC); Aesthetic Objectives (AO) and Operational Guidelines (OG) as presented in the Technical Support Document for Ontario Drinking Water Standards, Objectives and Guidelines (MOE, 2006).
2. Maximum Acceptable Concentration [MAC] under Health Canada's Drinking Water Guidelines
3. Aesthetic Objective under Health Canada's Drinking Water Guidelines
4. Treated water data not available because of mixing with Well 1 and Well 2 in historical data
5. MECP operational guideline

The iron and manganese concentrations for each well are within the historical ranges (from 2010 to 2015). Both iron and manganese concentrations in Well 2 were above the provincial aesthetic objectives (AO) and manganese concentrations in Well 3 exceeded the aesthetic objective.

Health Canada introduced a guideline in May 2019 establishing a maximum acceptable concentration (MAC) for manganese of 0.12 mg/L, an aesthetic objective of 0.02 mg/L and recommended a treated water goal of ≤0.015 mg/L for removal treatment plants. At present, no changes have been proposed to implement a MAC for manganese under the Ontario Drinking Water Standards; however, this information is presented for consideration of potential future regulatory changes. The manganese concentrations at both wells were below the Health Canada MAC but exceeded the Health Canada aesthetic objective¹.

The treated pH value for Well 2 is within the range of historical raw water pH values and similar to the historical treated pH value at Well 3. The treated water pH at Well 3, however, was lower than Well 2 and lower than the

¹ It should be noted that Mount Albert Well 1, which was not included in this study, has raw water manganese concentrations that reached the Health Canada MAC of 0.12 mg/L. This well is not currently in use.

historical treated water pH range for this well. The reason why the pH value was lower than the historical range is not known but could have been due to one or a combination of the following factors: fluctuations in raw water pH (see historical range), a higher chlorine dose on the sampling day than on historical sampling days, the use of a different pH probe, or sampling and analysis protocol (flow through cell).

3.4 Fill Cycle Sampling Results

The first round of distribution iron and manganese sampling was conducted while the wells were in operation (samples collected between 2:30 PM and 5:10 PM, August 1, 2019). During this period, the sodium silicate dose setpoint was 26 mg/L as combined Na₂O and SiO₂ solids of N® Clear Sodium Silicate Solution for Well 2 (i.e. 20 mg/L-SiO₂)² and 15 mg/L as combined Na₂O and SiO₂ solids of N® Clear Sodium Silicate Solution for Well 3 (i.e. 11 mg/L-SiO₂)².

Sampling results for Round 1 are presented in Attachment 3, including iron, manganese, silicon, along with on-site measurements for free and total chlorine (Cl), pH, temperature, turbidity and DO. The iron and manganese data are summarized in Table 3-4. Silicon and on-site measurements are discussed in Sections 3.2 and 3.6.

Iron levels measured were below the ODWS Aesthetic Objective of 0.3 mg/L at most locations with the exception of the supply from Well 2 (0.48 mg/L) and Station 6 (0.324 mg/L). Manganese concentrations exceeded both the current ODWS Aesthetic Objective of 0.05 mg/L and the Health Canada Aesthetic Objective of 0.02 mg/L at all locations, but no results exceeded the Health Canada Guideline MAC of 0.12 mg/L.

² Calculated assuming N® Clear Sodium Silicate Solution contains 37.86 wt % solids (combined Na₂O and SiO₂ solids) and 28.79 wt % of SiO₂. These percentages were taken from a certificate of analysis dated 05/09/2018, provided by York Region.

Table 3-4. Sampling Round 1 Results, Fill Cycle

Parameter	Location									
	Well 2	Well 3	1	2	3	4	5	6	7	8
Pipe Material	-	-	PVC	PVC	PVC	PVC	DI	DI	PVC/CPP	-
Total Fe (mg/L)	0.480	0.108	0.099	0.110 ² (0.094 to 0.136) ³	0.158	0.062	0.296	0.324	0.080 ² (0.069 to 0.102) ³	0.126
Dissolved Fe (mg/L)	0.402	0.046	0.075	0.008 ² (<0.010 to 0.023) ³	0.126	<0.010	0.227	0.239	0.035 ² (<0.010 to 0.058) ³	0.105
% Dissolved Fe ¹	84	43	76	7 ² (0 to 23) ³	80	0	77	74	43 ² (0 to 83) ⁴	83
Particulate Fe ¹	0.078	0.062	0.024	0.103 ² (0.078 to 0.136) ³	0.032	0.062	0.067	0.085	0.045 ² (0.012 to 0.069) ³	0.021
Total Mn (mg/L)	0.071	0.037	0.027	0.026 ² (0.025 to 0.028) ³	0.034	0.017	0.056	0.058	0.052 ² (0.050 to 0.053) ³	0.040
Dissolved Mn (mg/L)	0.058	0.025	0.012	0.003 ² (0.002 to 0.003) ³	0.023	0.006	0.046	0.047	0.037 ² (0.035 to 0.038) ³	0.028
% Dissolved Mn ¹	82	68	44	10 ² (8 to 12) ³	68	35	82	81	72 ² (70 to 73)	70
Particulate Mn ¹	0.013	0.012	0.015	0.024 ² (0.022 to 0.024) ³	0.011	0.011	0.010	0.011	0.015 ² (0.014 to 0.015)	0.012

Notes

1. Calculated from dissolved and total measurements.
2. Average of replicate samples. Average was calculated assuming a concentration of 0 mg/L for measurements that were less than the method detection limit.
3. Range of measurements on replicate sample.

3.4.1 Total Iron and Manganese

Iron

Iron levels between Well 2 and Well 3 are very different, with Well 2 having total iron concentrations of 0.480 mg/L, roughly four times higher than those from Well 3 (0.108 mg/L). Measured iron concentrations in the distribution system were all much closer to the levels measured in Well 3, with the exception of levels measured at Stations 5 (0.296 mg/L) and 6 (0.324 mg/L), which approached Well 2 levels. It is likely that given their location, these stations received a significant proportion of water directly from Well 2, explaining the higher levels. While it appeared that there was an opportunity to use the water quality model to estimate the proportion of supply coming from each well at each station, it was determined that due to the sensitivity of the model, significantly more data than was currently available, including pipe friction factors, pump cycle data and correlated sampling data, would be required to provide confidence in the estimations. As a result, the analysis is presented in relative terms based on the location of the sampling locations in relation to the wells and taking into account the layout of the distribution system.

It is noted that the measured level at Station 4 (0.062 mg/L) was lower than either of the well concentrations (current or average historical) which would suggest that iron deposition in the distribution system is occurring and, given observations previously noted of coloured water during flushing, that therefore sequestration is not providing effective iron control. While levels lower than Well 2 were measured at Stations 1, 5 and 6, again seemingly suggesting iron deposition, it is also possible that there was some mixing with the lower iron concentration water supplied by Well 3.

Station 7; however, is supplied only with water from Well 3 while the wells are operating, due to its location and would, therefore, be expected to have similar total iron concentrations to Well 3; however, the measured levels of 0.080 mg/L were lower, providing further evidence of deposition in the distribution system.

Manganese

Total manganese concentrations measured at Well 2 were on the high end of the historical data range (Table 3-3), resulting in a significant difference in total manganese concentrations between Well 2 and Well 3.

There was large variability observed in manganese concentrations between sampling stations, with total manganese concentrations ranging from 0.017 mg/L (Station 4) to 0.058 mg/L (Station 6). The lowest manganese concentrations appear to be in areas with higher predicted water ages, based on the hydraulic modelling (Sampling Stations 2,3,4; see Hydraulic Analysis Study). Concentrations at these stations were below the concentrations measured at the wells, as well as the minimum historical values measured at the wells, suggesting that Mn was deposited in the distribution system between the wells and these sampling locations. It is unclear whether there is a pipe material impact given that the pipes in the areas with the higher water ages were PVC and are newer than the ductile iron pipes.

At Station 7, the measured manganese concentration was substantially higher (almost 1.5 times) the concentration of the supply from Well 3. It is noted that the sample at Station 7 was taken 2 hours after the well sample and while it is possible that the manganese concentration from Well 3 had fluctuated over time, this degree of fluctuation would be uncommon in that short a time period; therefore, these results suggest that release of legacy manganese from the distribution system may have been occurring. It is noted that the levels do reach the upper end of the range of historical values measured for treated water from Well 3.

3.4.2 Dissolved Iron and Manganese

The aim of sequestrant addition is to maintain iron and manganese in dissolved form to limit deposition and discoloured water in the distribution system. While the tank was filling, it was expected that the samples from the wells and from stations that likely were receiving water from the wells with little lag time (Wells 2 and 3, and Stations 5, 6, 7 and 8) would have the highest proportion of iron and manganese in the dissolved form. Stations further in the system or at dead-ends such as Stations 1, 2 and 4 were expected to have higher particulate iron and manganese concentrations because of higher water age and/or contribution of water coming from the elevated tower.

The percentage of iron and manganese in the dissolved form, while the wells were operating, is shown in Table 3-4, and ranged from 0% to 83%. In general, locations further from the wells (Stations 1, 2, 3, and 4) and locations with higher predicted water ages (Stations 2, 3, 7) had lower proportions of dissolved iron and manganese and the majority of the iron or manganese was in particulate form at some of these locations. The sequestration performance at Well 2 and Stations 5, 6, receiving fresher water from the wells, was better with 74-84% of iron and manganese in the dissolved form. Well 3 and Station 7, even with low water age, had low proportions of dissolved iron and manganese implying poor sequestration at these locations. Sequestration of water entering the tower (Station 8) was also better than at Stations 1-4, with 83% of iron and 70% of manganese entering the tower in the dissolved form.

The sequestration results did not correlate exactly with visual inspection of the filter papers used when collecting filtered water samples (Attachment 3). During the fill cycle, Station 6 and Well 2 had no visible iron staining on their filter papers, whereas Stations 2³ and 8 had visible iron staining on their filter papers despite the fact that they had similar or lower amounts of particulate iron. Water from Station 4 had a smaller proportion of its iron (only 8%) in the dissolved state but because of the lower particulate iron concentration (0.062 mg/L), no staining was visible on the filter paper. This would suggest that filter paper inspection, on its own, may not be a robust diagnostic tool for sequestration performance. It is proposed that if filter paper inspection is used, it should be done in conjunction with total and dissolved iron measurements, total and dissolved manganese measurements, and/or turbidity.

3.5 Drain Cycle Sampling Results

Iron and manganese sampling Rounds 2, 3 and 4 were conducted during the drain cycle (well pumps not in operation). Total iron and manganese, and dissolved iron and manganese results are discussed in the following subsections.

3.5.1 Total Iron and Manganese

Sampling results for the Rounds 2, 3 and 4 are presented in Attachment 3, including iron, manganese, silicon, along with on-site measurements for free and total chlorine (Cl), pH, temperature, turbidity and DO for Rounds 2 and 3. Figure 3-6 to Figure 3-9 summarizes the results for iron and manganese (total and dissolved). Silicon and on-site measurements are discussed in Sections 3.2 and 3.6.

³ All replicates had staining on the filters, including the replicate set with 0.078 mg/L particulate iron.

Iron

Figure 3-6 shows the iron concentrations with respect to time.

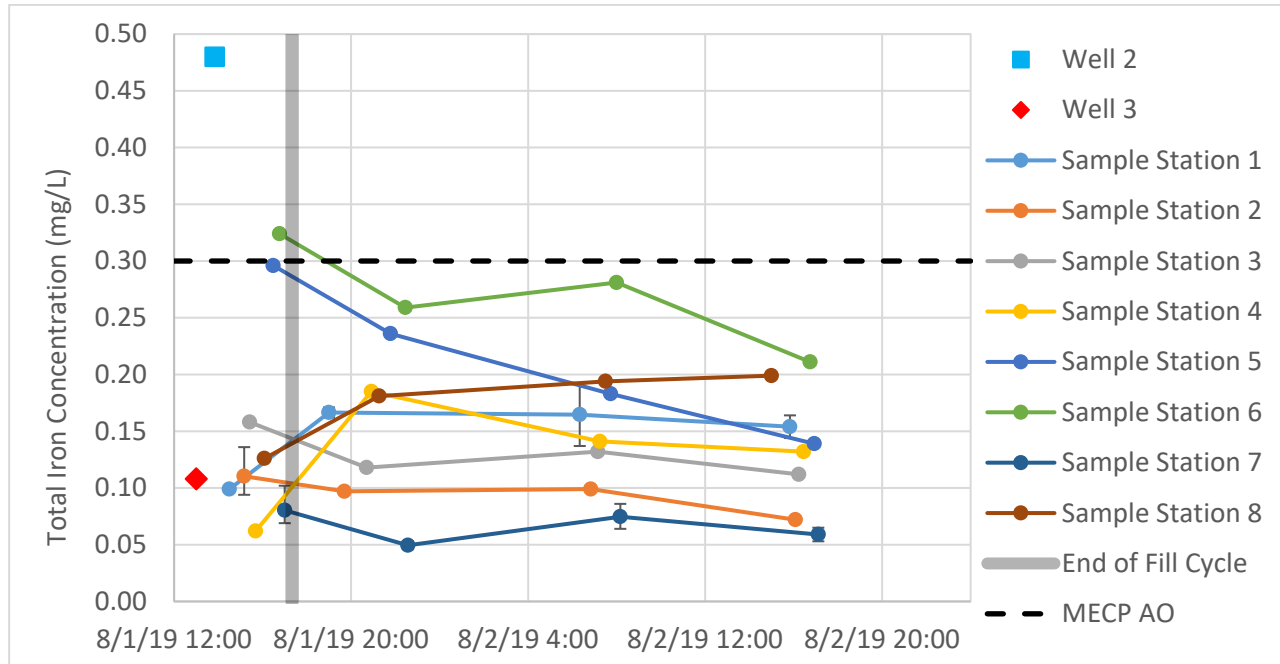

Figure 3-6. Total Iron Results, Rounds 1-4

Error bars represent minimum and maximum from replicate samples

Locations likely receiving some water from Well 2 (Stations 5 and 6) had higher iron concentrations compared to sample stations receiving water primarily from Well 3 (Station 7). Stations 5 and 6 had declining iron concentrations, suggesting that iron deposition was occurring gradually there or that mixing was occurring (e.g. from changes in water flow direction) with water that had lower iron concentrations (e.g. from Well 3); it cannot be firmly concluded whether the downward trend was due to deposition or mixing at these stations. Station 8 (elevated tank) started with low iron concentrations, but the iron concentration increased once the tower started draining, suggesting the presence of iron deposits in the elevated tank were being released from the tank into the distribution system. Sites close to the tower either show an increase in iron concentration to levels similar to those at the tower followed by a decrease (Station 4) or do not have increases similar to those seen in the tower (Station 8), suggesting that the iron coming from the elevated tank is deposited in the distribution system quickly.

Manganese

Figure 3-7 shows the manganese concentrations with respect to time.

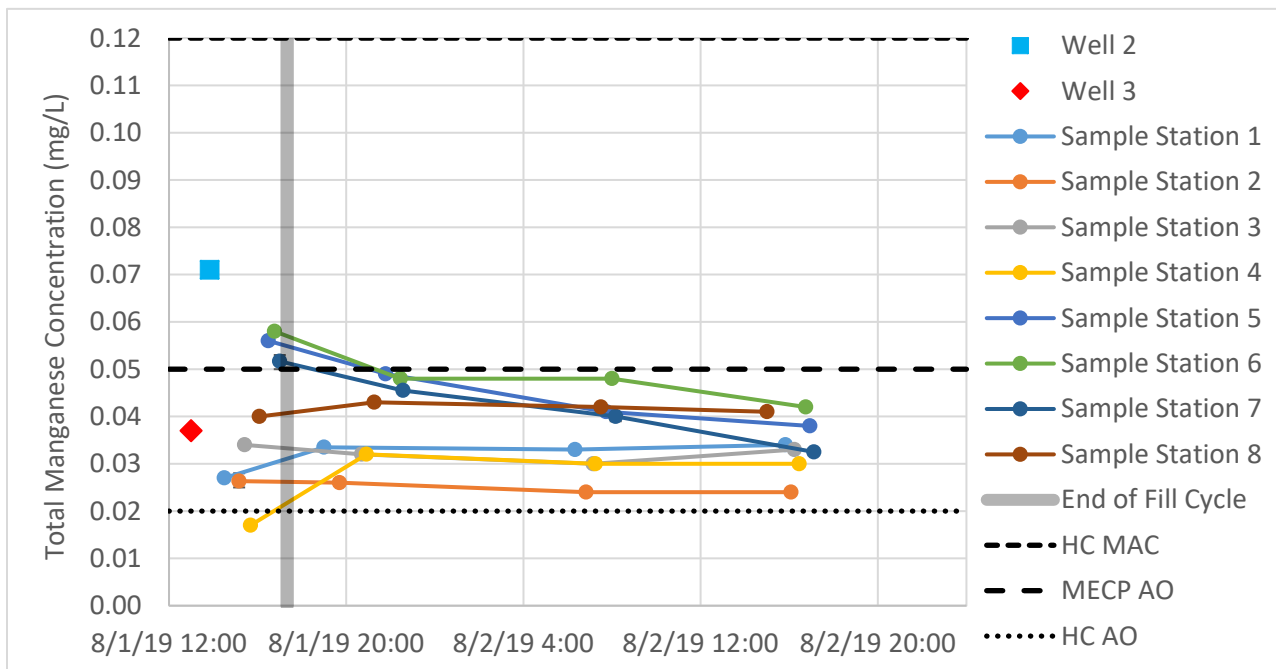

Figure 3-7. Total Manganese Results, Rounds 1-4
 Error bars represent minimum and maximum from replicate samples

Manganese concentrations at Sampling Stations 1, 2, 3, and 4 were all below the treated water manganese concentrations from the wells and were below the lowest historical treated and raw water manganese concentrations, suggesting that manganese deposited in the system between the wells and these points. These locations are all areas further in the system from the wells and Stations 2, 3, and 4, in particular, have comparatively high water ages (Hydraulic Analysis Study).

Manganese concentrations at Sampling Stations 5, 6, and 7 also all show a decreasing trend. As with iron, the trend suggests that either deposition was occurring or that mixing was occurring at these points (e.g. from changes in water flow direction) with water that had lower manganese concentrations (e.g. from Well 3). It cannot be firmly concluded whether the downward trend was due to deposition or mixing at Stations 5 and 6; however, at Station 7, it is likely that manganese deposition did occur over the 24 hour period from Sampling Round 1 to Round 4 given the sustained downward trend over time and the fact that the final manganese concentration at Station 7 was lower than the initial and historical manganese concentrations observed at both wells (Table 3-3).

3.5.2 Dissolved Iron and Manganese

Iron

Dissolved iron results are presented in Figure 3-8.

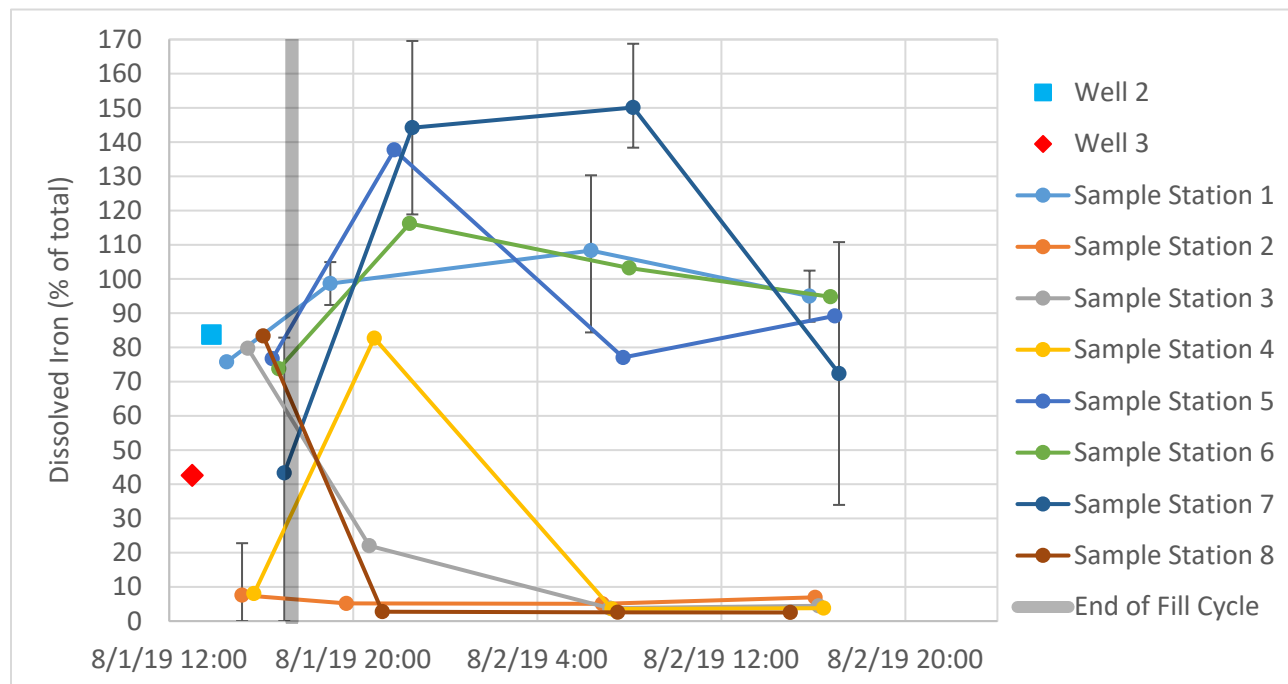

Figure 3-8. Dissolved Iron Results, Rounds 1-4

Error bars represent minimum and maximum calculated from replicate samples

The dissolved iron results were more variable than expected, with the difference in minimum and maximum per cent dissolved iron calculated from replicates ranging from approximately 12 to 82%. Furthermore, several samples at Station 7 and one sample at Station 5 and at Station 6 were also reported as having dissolved iron concentrations greater than the total iron concentration (i.e. per cent dissolved iron greater than 100%). It is theoretically impossible to have a water sample with a dissolved iron concentration greater than 100%. The reason why the per cent dissolved iron was greater than 100% in some cases is unknown. It is unlikely that this was due to laboratory analytical error given the lab QA/QC results (Section 3.1.1); however, it could have been due to one of the following factors:

- Analytical variability in the iron measurements
- Total iron and dissolved iron samples at each station were collected sequentially, in separate bottles. If there was temporal variability in the total iron concentration in the distribution system, it could have resulted in higher iron concentrations in the dissolved iron sampling bottle. For example, if a “discrete volume” of water with a higher total iron concentration flowed by a sampling location while the dissolved iron sample concentration was taken, it would result in the calculated per cent dissolved to appear to be greater than 100%.
- There may have been some low level contamination or cross-contamination of samples, given that some sample blanks showed evidence of iron contamination (Section 3.1.2).

Despite the limitations of the dissolved iron results, broad trends in the data can still be observed. Furthermore, as discussed later in this section, similar trends were seen with the dissolved manganese results lending further credence to conclusions that can be drawn from the iron results.

The dissolved iron results can be divided into two main groups: Stations 1, 5, 6 and 7 had high dissolved iron concentrations during the drain cycle (above 60% of total iron concentration), while Stations 2, 3, 4 and 8 showed low proportions of dissolved iron during the drain cycle (generally less than 20% and often below the detection limit of 0.01 mg/L). The high dissolved iron locations can be characterized as locations with dissolved oxygen concentrations that were generally below 1 mg/L. The low dissolved iron locations had higher dissolved oxygen concentrations (between 2 and 6 mg/L) and as a result likely received water that had passed through the elevated tank, where the water would have been aerated and increased in water age. Areas with low dissolved iron concentrations also were in areas that generally had higher water ages (Hydraulic Analysis Study, November 22, 2019).

It was also observed that Stations 3 and 8 had a higher proportion of dissolved iron while they received low-oxygen water while the tank was filling, but once the drain cycle started and they received water from the tank, the proportion of dissolved iron present at the station dropped.

Overall the dissolved iron results suggest iron is converted from dissolved to particulate form within the tank. This conversion could be due to factors such as to age of the water in the tank, the presence of tank sediments that are mixed with the supply, or the impact of aeration of the inlet on sequestration performance.

Filter paper inspection indicated that Stations 2, 3, 4 and 8 had higher concentrations of particulate iron as compared to the other four Stations 1, 5, 6 and 7 (Attachments 2 and 3). The filter paper results correlated well with most particulate iron data, showing that locations that had high particulate iron would likely have stained filters. Staining was detected in samples with as little as 0.072 mg/L of particulate iron (S Station 2, Round 4). This differed from the fill cycle, where there was not a clear correlation between the filter staining and particulate iron. The reason for the difference between the fill and drain cycle is not known.

Manganese

Figure 3-9 shows the dissolved manganese results.

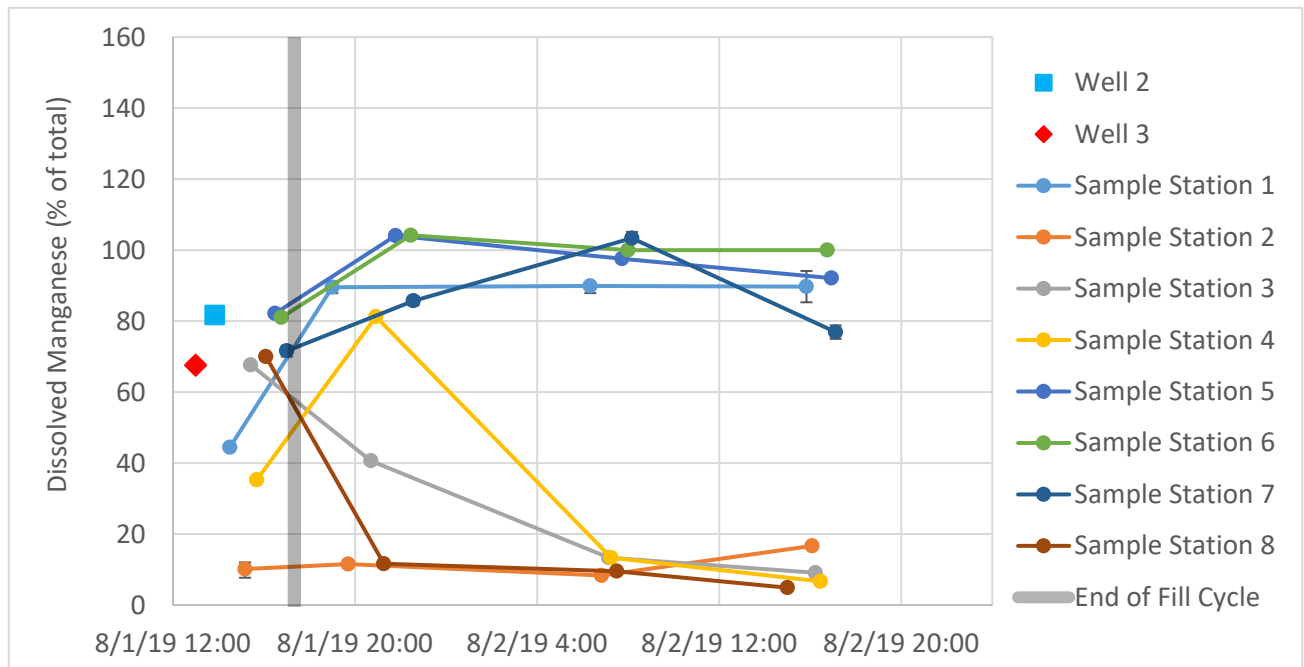

Figure 3-9. Dissolved Manganese Results, Rounds 1-4
 Error bars represent minimum and maximum calculated from replicate samples

The broad trends for dissolved manganese were similar in most cases to dissolved iron (Figure 3-9). Again, Stations 1, 5, 6 and 7 showed high proportions of dissolved manganese, generally 90% or better. Stations 2, 3,

4 and 8, which likely received water from the elevated tank, showed less than 20% of the manganese in the dissolved form 12 hours or more after the wells had stopped operating.

3.6 Other Parameters

3.6.1 Silicon

Silicon results are shown in Figure 3-10.

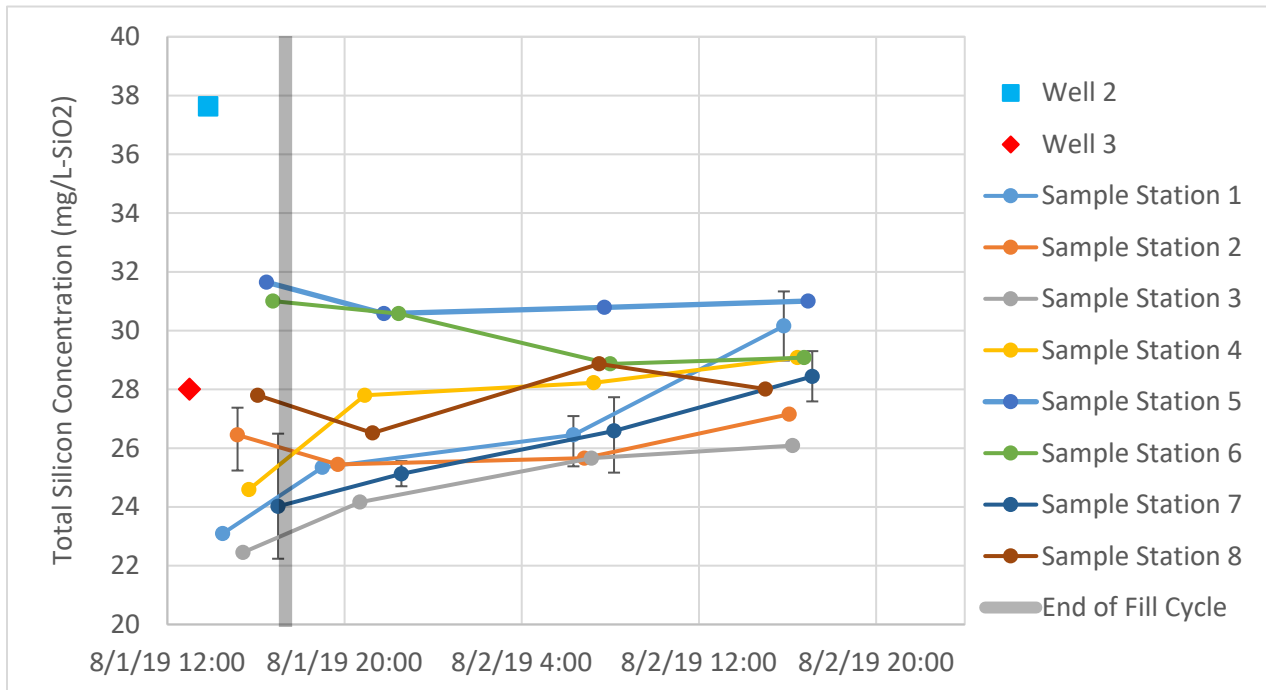

Figure 3-10. Total Silicon, Rounds 1-4
 Error bars represent minimum and maximum from replicate samples

Silicon concentrations at several locations were lower than the concentration initially measured at both wells (Sample locations 1,2,3, 7). Variability in the silicon measurements may explain some of the difference between the silicon concentration in the wells and the concentrations measured in the system⁴; however, in at least one case (Station 7) it does not fully explain the difference⁵ and the silicon results imply that either there was a change (drop) in sodium silicate being dosed to the system by Well 3 or that the silicon was depositing within the distribution system between Well 3 and the sampling stations.

It was also noted that several sampling locations (Sample locations 1,3,4,7) showed an increase in silicon concentration over time. Again, this apparent increase could be due to variability in the silicon measurements; however, it is also possible that it is due to changes in sodium silicate dosing over time.

⁴ For example, the lab quality assurance program indicated that duplicate analysis could result in a relative per cent difference from 3.6 to 13.7%. Assuming the worst case, a relative per cent difference of 13.7%, a of the duplicate measurement at Well 2 (28 mg/L-SiO₂) could range between 24.4 mg/L-SiO₂ and 32.1 mg/L-SiO₂. Under the same assumptions, a of the duplicate measurement at Well 3 (37.6 mg/L-SiO₂) could range between 32.8 and 43.1 mg/L-SiO₂.

⁵ Location 7 receives water primarily from Well 3, which had an initial silicon concentration of 37.6 mg/L-SiO₂ in Round 1. The silicon concentration at Station 7 ranged from 24.0 mg/L-SiO₂ to 28.0 mg/L-SiO₂. Even accounting for the greatest observed relative per cent difference between duplicate measurements (13.7%, see Section 3.1.1) the concentrations observed at location 7 are lower than that at Well 3.

Region staff have noted that there are issues with the accuracy and reliability of the current peristaltic pumps feeding solidum silicate. Such issues could result in fluctuations in the amount of silicon dosed to the distribution system and explain some of the trends seen in the silicon concentrations in the distribution system.

3.6.2 Turbidity

Turbidity results were generally between 0.02 NTU and 0.40 NTU. Results were variable, due largely to de-gassing that quickly created air bubbles that interfered with measurements. No clear trends were observed and no correlations were noted with any other water quality parameter.

3.6.3 pH, Temperature and Chlorine

More frequent data for onsite measurements are included in the water quality sampling used for hydraulic modelling, which includes a total of 20 rounds of sampling over two separate dates. This data is a more complete set for examining changes in pH, temperature and chlorine.

During the iron and manganese sampling, pH values were stable, especially when the wells were not operating. pH values at the sampling stations were generally between 7.6 and 7.8. At most locations, the pH remained within a range of 0.04 units once the wells stopped operating. Samples stations fed with water from the elevated tank all had similar pH (about 7.7). Due to the use of chlorine gas at Well 3 instead of sodium hypochlorite, locations fed with water from Well 3 had a lower pH (7.53 at Station 7).

Water temperature ranged from 9.7°C, at Station 7 sampling round 1 to 17.4 °C at Station 4 sampling round 1. Water temperature had some correlation to water age but can also be impacted by watermain depth and/or flow path (i.e. previous pipes and conditions travelled).

Chlorine concentrations remained at or above 1 mg/L as free chlorine at all sample locations, regardless of water age, temperature, pipe material or pipe diameter. As a result, the ORP at all locations was generally between 750 and 790 mV, which is representative of a water with a robust free chlorine residual. Further, there was little variation between the free chlorine residual and total chlorine residual measurements and no obvious trends, indicating a consistent biostability in the distribution system. Similar to the model predictions, chlorine concentrations were found to be generally lower where water age was calculated to be highest (Stations 1 to 4, near the elevated tank and at dead-ends), but still remained within target. Also, it is noted that sample stations with warmer water reported lower chlorine residuals since chlorine decay rates are generally expected to double with each 10°C increase in temperature.

4. Summary of Major Findings

Overall, the results suggest that during the sampling on August 1 and 2, 2019, iron and manganese deposition was occurring in the system and, as a result that the current sodium silicate treatment was not effectively maintaining iron and manganese in the dissolved form throughout the Mount Albert DWS. They also suggest that water age and some factors associated with the tank (e.g. water age, presence of sediments, aeration of the water, or other factors) may be currently having a negative impact on sequestration effectiveness.

The results and analysis from this study suggest that:

- There is evidence of some iron and manganese deposition between the wells and sampling points in the distribution system
- Sequestration of water from Well 3 was not maintaining iron in the dissolved form, even when the water age was low, given that during the fill cycle the percent dissolved iron was low at Well 3 and at Station 7
- Iron is converting from dissolved to particulate form within Mount Albert Elevated Tank Ninth Line. Factors that could be contributing to sequestration performance include water age in the tank, the presence of tank sediments, or the impact of aeration of the inlet increasing the dissolved oxygen levels.
- There are likely iron deposits in the tank (as of the time of sampling) and some of this iron was released to the distribution system during the drain cycle

- Areas with higher water age and that had water that had likely passed through the tank had very low dissolved iron and manganese concentrations
- Manganese concentrations at Well 3 either fluctuated over time or legacy manganese was released between Well 3 and Station 7
- Visual inspection of filters did not always correlate well with dissolved and particulate iron or manganese concentrations and may not be a reliable indicator of sequestrant performance

It was not possible to determine if pipe material had an impact on sequestration performance given that areas with a higher water age also tended to have PVC pipe and areas with lower water age also had DI pipes.

Attachment 1 Water Quality Sampling Plan

Refer to Appendix C

Attachment 2 Summary of Sampling Results

Sampling Results, Fill Cycle (Round 1)

Parameter	Location									
	Well 2	Well 3	1	2	3	4	5	6	7	8
Pipe Material	-	-	PVC	PVC	PVC	PVC	DI	DI	PVC/CPP	-
Total Fe (mg/L)	0.480	0.108	0.099	0.110 ² (0.094 to 0.136) ³	0.158	0.062	0.296	0.324	0.080 ² (0.069 to 0.102) ³	0.126
Dissolved Fe (mg/L)	0.402	0.046	0.075	0.008 ² (<0.010 to 0.023) ³	0.126	<0.010	0.227	0.239	0.035 ² (<0.010 to 0.058) ³	0.105
% Dissolved Fe ¹	84	43	76	7 ² (0 to 23) ³	80	0	77	74	43 ² (0 to 83)	83
Particulate Fe ¹	0.078	0.062	0.024	0.103 ² (0.078 to 0.136) ³	0.032	0.062	0.067	0.085	0.045 ² (0.012 to 0.069) ³	0.021
Total Mn (mg/L)	0.071	0.037	0.027	0.026 ² (0.025 to 0.028) ³	0.034	0.017	0.056	0.058	0.052 ² (0.050 to 0.053) ³	0.040
Dissolved Mn (mg/L)	0.058	0.025	0.012	0.003 ² (0.002 to 0.003) ³	0.023	0.006	0.046	0.047	0.037 ² (0.035 to 0.038) ³	0.028
% Dissolved Mn ¹	82	68	44	10 ² (8 to 12) ³	68	35	82	81	72 ² (70 to 73) ³	70
Particulate Mn ¹	0.013	0.012	0.015	0.024 ² (0.022 to 0.024) ³	0.011	0.011	0.010	0.011	0.015 ² (0.014 to 0.015) ³	0.012
Total Silicon (mg/L-SiO ₂)	37.6	28.0	23.1	26.5 ³ (24.4 to 28.0)	22.5	24.6	31.7	30.6	24.0 ³ (21.4 to 26.7)	27.8
Dissolved Silicon (mg/L-SiO ₂)	35.1	23.3	25.4	25.8 ³ (24.6 to 26.7)	22.2	22.5	25.2	26.9	20.8 ³ (19.1 to 23.3)	25.9
% Dissolved Silicon, as SiO ₂ ¹	93	83	110	98 ³ (93 to 101)	99	91	80	88	87 ³ (80 to 94)	93
Average Free Cl (mg/L)	1.14	1.78	1.07	1.03	0.91	1.01	1.33	1.24	1.45	1.32
Average Total Cl (mg/L)	1.27	1.87	1.13	1.15	1.08	1.17	1.43	1.48	1.72	1.52

Sampling Results, Fill Cycle (Round 1)

Parameter	Location									
	Well 2	Well 3	1	2	3	4	5	6	7	8
Temperature (°C)	9.97	9.23	15.7	14.3	14.6	17.4	11.7	11.5	9.7	13.1
pH	7.85	7.48	7.57	7.69	7.59	7.62	7.7	7.73	7.52	7.59
Turbidity (NTU)	0.03	0.13	0.11	0.18	0.24	0.12	0.08	0.02	0.02	0.44
DO (mg/L)	0.47	0.5	0.37	4.68	0.5	2.53	0.72	0.4	0.32	0.95

Notes:

1. Calculated from dissolved and total measurements
2. Average of replicate samples. Average was calculated assuming a concentration of 0 mg/L for measurements that were less than the method detection limit.
3. Range of measurements on replicate sample

Sampling Results, Drain Cycle (Rounds 2, 3 and 4)

Parameter	Sample Station							
	1	2	3	4	5	6	7	8
Pipe Material	PVC	PVC	PVC	PVC	DI	DI	PVC/PPP	-
Sampling Round 2								
Total Fe (mg/L)	0.167 ² (0.162 to 0.171) ⁴	0.097	0.118	0.185	0.236	0.259	0.050 ² (0.046 to 0.053) ⁴	0.181
Dissolved Fe (mg/L)	0.164 ² (0.158 to 0.170) ⁴	<0.010	0.026	0.153	0.325	0.301	0.071 ² (0.063 to 0.078) ⁴	<0.010
% Dissolved Fe ¹	99 ² (92 to 105) ⁴	0	22	83	138	116	142 ² (119 to 170) ⁴	0
Particulate Fe (mg/L)	0.003 ² (-0.008 to 0.013) ⁴	0.097	0.092	0.032	-0.089	-0.042	-0.032 ² (-0.032 to -0.01) ⁴	0.181
Total Mn (mg/L)	0.034 ² (0.033 to 0.034) ⁴	0.026	0.032	0.032	0.049	0.048	0.046 ² (0.045 to 0.046) ⁴	0.043
Dissolved Mn (mg/L)	0.030 ² (0.029 to 0.031) ⁴	0.003	0.013	0.026	0.051	0.050	0.039 ² (0.038 to 0.040) ⁴	0.005
% Dissolved Mn ¹	90 ² (88 to 91) ⁴	12	41	81	104	104	86 ² (84 to 87) ⁴	12
Particulate Mn (mg/L)	0.004 ² (0.003 to 0.004) ⁴	0.023	0.019	0.006	-0.002	-0.002	0.070 ² (0.006 to 0.007) ⁴	0.038
Total SiO ₂ (mg/L)	25.3 ² (24.6 to 26.1)	25.4	24.2	27.8	30.6	28.9	25.1 ² (24.6 to 25.7) ⁴	26.5
Dissolved SiO ₂ (mg/L)	25.2 ² (25.2 to 25.2)	24.8	23.5	26.9	31.4	30.8	23.7 ² (23.3 to 24.2) ⁴	26.3
% Dissolved SiO ₂ ¹	100 ² (97 to 103) ⁴	97	97	97	103	107	94 ² (94 to 95) ⁴	99
Average Free Cl (mg/L)	1.19	1.07	1.26	1.13	1.20	1.28	1.57	1.21
Average Total Cl (mg/L)	1.38	1.26	1.37	1.28	1.35	1.43	1.73	1.30
Temperature (°C)	15.8	13.9	14.1	16.2	12.3	13.6	11.0	15.4
pH	7.63	7.7	7.63	7.66	7.7	7.7	7.53	7.76
Turbidity (NTU)	0.06	0.33	0.33	0.12	0.1	0.09	0.03	0.27
DO (mg/L)	0.37	4.47	5.52	4.41	1.91	4.87	0.39	5.60

Parameter	Sample Station							
	1	2	3	4	5	6	7	8
Sampling Round 3								
Total Fe (mg/L)	0.165 ² (0.137 to 0.192) ⁴	0.099	0.132	0.141	0.183	0.281	0.075 ² (0.064 to 0.086) ⁴	0.194
Dissolved Fe (mg/L)	0.176 ² (0.151 to 0.215) ⁴	<0.010	<0.010	<0.010	0.141	0.290	0.111 ² (0.106 to 0.119) ⁴	<0.010
% Dissolved Fe ¹	108 ² (84 to 130) ⁴	0	0	0	77	103	150 ² (138 to 169) ⁴	0
Particulate Fe	-0.011 ² (-0.050 to 0.030) ⁴	0.099	0.132	0.141	0.042	-0.009	-0.036 ² (-0.044 to -0.032) ⁴	0.194
Total Mn (mg/L)	0.033 ² (0.033 to 0.033) ⁴	0.024	0.030	0.030	0.041	0.048	0.040 ² (0.039 to 0.042) ⁴	0.042
Dissolved Mn (mg/L)	0.030 ² (0.029 to 0.030) ⁴	0.002	0.004	0.004	0.040	0.048	0.041 ² (0.040 to 0.043) ⁴	0.004
% Dissolved Mn ¹	90 ² (88 to 91) ⁴	8	13	13	98	100	103 ² (102 to 105) ⁴	10
Particulate Mn	0.003 ² (0.003 to 0.004) ⁴	0.022	0.026	0.026	0.001	0.000	-0.001 ² (-0.002 to -0.001) ⁴	0.038
Total SiO ₂ (mg/L)	26.5 ² (25.0 to 28.4) ⁴	25.7	25.7	28.2	30.8	29.1	26.6 ² (24.4 to 28.4) ⁴	28.9
Dissolved SiO ₂ (mg/L)	28.2 ² (27.2 to 28.9) ⁴	23.1	25.9	28.9	28.0	32.9	26.0 ² (24.6 to 27.2) ⁴	27.2
% Dissolved SiO ₂ ¹	107 ² (95 to 115) ⁴	90	101	102	91	113	98 ² (91 to 111) ⁴	94
Average Free Cl (mg/L)	1.12	1.11	1.11	1.13	1.25	1.19	1.45	1.22
Average Total Cl (mg/L)	1.26	1.21	1.27	1.25	1.36	1.28	1.61	1.31
Temperature (°C)	16.0	13.2	15.5	17.2	13.0	14.3	13.0	15.5
pH	7.66	7.72	7.75	7.76	7.63	7.72	7.54	7.77
Turbidity (NTU)	0.07	0.2	0.32	0.27	0.14	0.07	0.09	0.28
DO (mg/L)	0.54	4.01	5.20	5.60	0.60	0.44	0.47	5.88

Parameter	Sample Station							
	1	2	3	4	5	6	7	8
Sampling Round 4								
Total Fe (mg/L)	0.154 ² (0.144 to 0.164) ⁴	0.072	0.112	0.132	0.139	0.211	0.059 ² (0.053 to 0.065) ⁴	0.199
Dissolved Fe (mg/L)	0.147 ² (0.126 to 0.168) ⁴	<0.010	<0.010	<0.010	0.124	0.200	0.045 ² (0.018 to 0.072) ⁴	<0.010
% Dissolved Fe ¹	95 ² (88 to 102) ⁴	0	0	0	89	95	72 ² (34 to 111) ⁴	0
Particulate Fe	0.007 ² (-0.004 to 0.018) ⁴	0.072	0.112	0.132	0.015	0.011	0.014 ² (-0.007 to 0.035) ⁴	0.199
Total Mn (mg/L)	0.034 ² (0.034 to 0.034) ⁴	0.024	0.033	0.030	0.038	0.042	0.033 ² (0.032 to 0.033) ⁴	0.041
Dissolved Mn (mg/L)	0.031 ² (0.029 to 0.032) ⁴	0.004	0.003	0.002	0.035	0.042	0.025 ² (0.024 to 0.026) ⁴	0.002
% Dissolved Mn ¹	90 ² (85 to 94) ⁴	17	9	7	92	100	77 ² (75 to 79) ⁴	5
Particulate Mn	0.004 ² (0.002 to 0.005) ⁴	0.020	0.030	0.028	0.003		0.008 ² (0.007 to 0.008) ⁴	0.039
Total SiO ₂ (mg/L)	30.2 ² (29.1 to 31.2) ⁴	27.2	26.1	29.1	31.0	29.5	28.4 ² (28.0 to 28.9) ⁴	28.0
Dissolved SiO ₂ (mg/L)	29.4 ² (28.2 to 30.6) ⁴	24.6	29.1	27.6	27.8	29.7	27.4 ² (26.5 to 28.2) ⁴	27.4
% Dissolved SiO ₂ ¹	98 ² (97 to 98) ⁴	91	111	95	90	101	96 ² (95 to 98) ⁴	98

Notes:

1. Calculated from dissolved and total measurements.
2. Average of replicate samples. Average was calculated assuming a concentration of 0 mg/L for measurements that were less than the method detection limit.
3. Range of measurements on replicate sample.

Attachment 3 Filter Paper Pictures

Photos of Filter Papers

**Mount Albert Distribution System Sampling
August 1-2, 2019**

	Round 1	Round 2	Round 3	Round 4
Location 1 1 Mainprize Crescent, Mount Albert				
Location 2 19451 Centre St, Mount Albert				
Location 3 405 King St E, Mount Albert				
Location 4 74 Manor Glen Crescent, Mount Albert				
Location 5 Millennium Park at King St and Albert St, Mount Albert <i>- order may not be correct</i>				

Figure 1: Photo of Filter Papers Used for Sampling Dissolved Metal at Mount Albert, Sample Stations 1 to 5

**Mount Albert Distribution System Sampling
August 1-2, 2019**

	Round 1	Round 2	Round 3	Round 4
Location 6 5517 Mount Albert Rd, Mount Albert <i>- may not be in order</i>				
Location 7 18855 Centre St, Mount Albert				
Location 8 North Elevated Tank 19178 Ninth Line, Mount Albert				

Figure 2. Photo of Filter Papers Used for Sampling Dissolved Metal at Mount Albert, Sample Stations 6 to 8

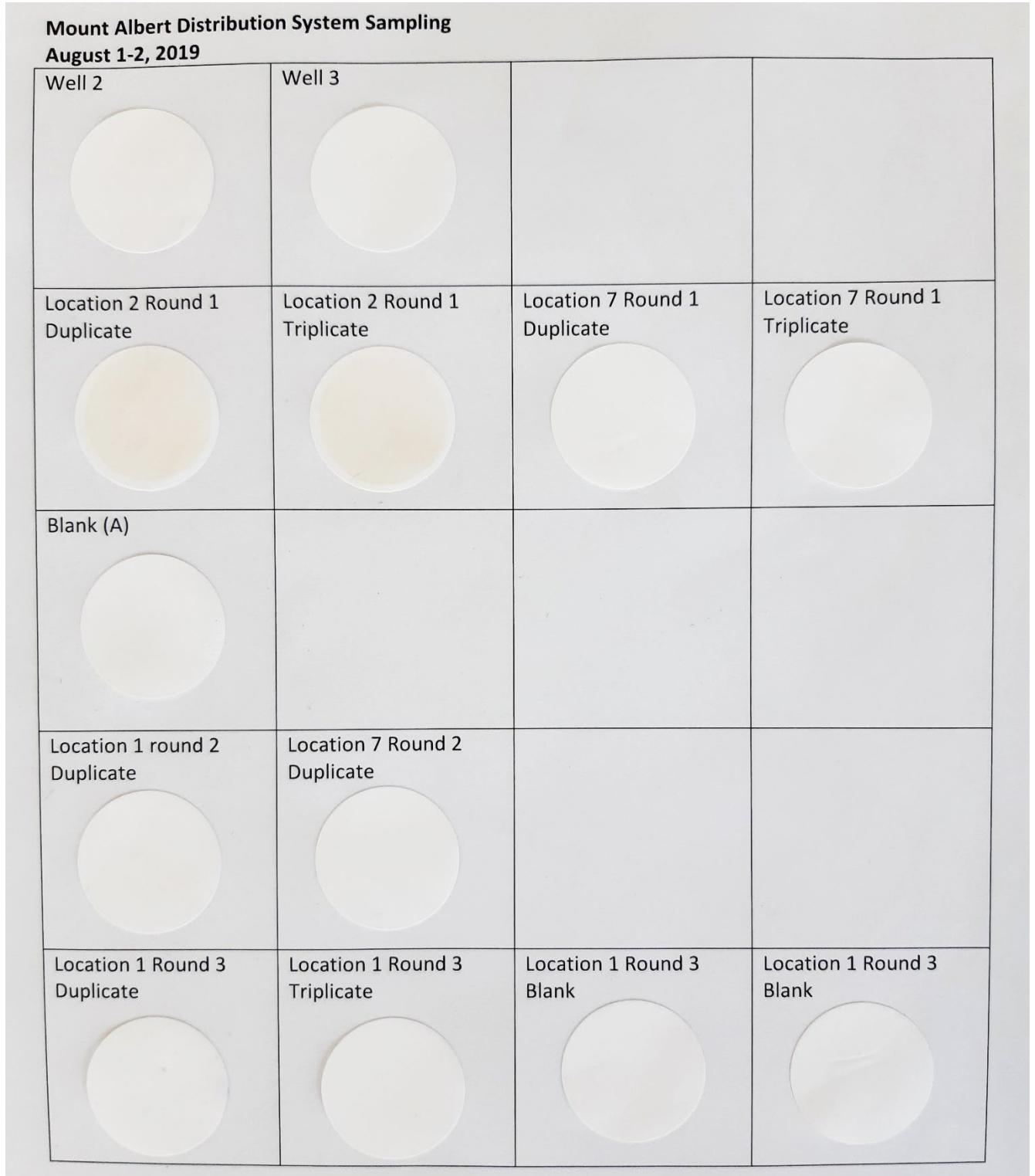

Figure 3. Photo of Filter Papers Used for Sampling Dissolved Metal at Mount Albert, Wells 2 and 3, Blanks and Duplicates

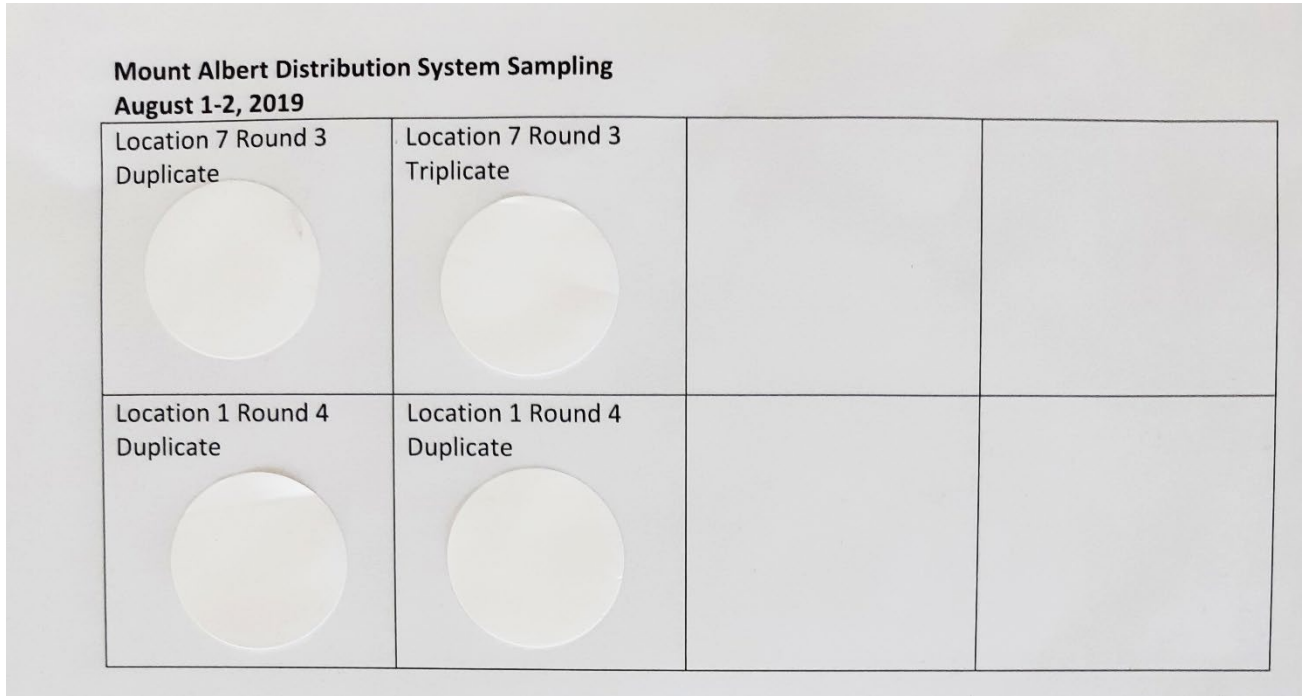

Figure 4. Photo of Filter Papers Used for Sampling Dissolved Metal at Mount Albert, Duplicates for Rounds 3 and 4

Trends for Individual Sample Locations

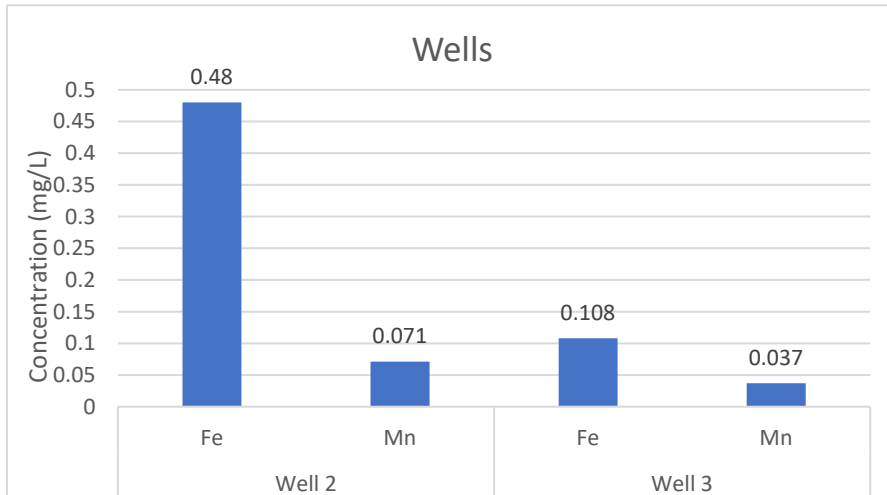

Figure 5. Total Iron and Manganese Concentrations in Wells 2 and 3

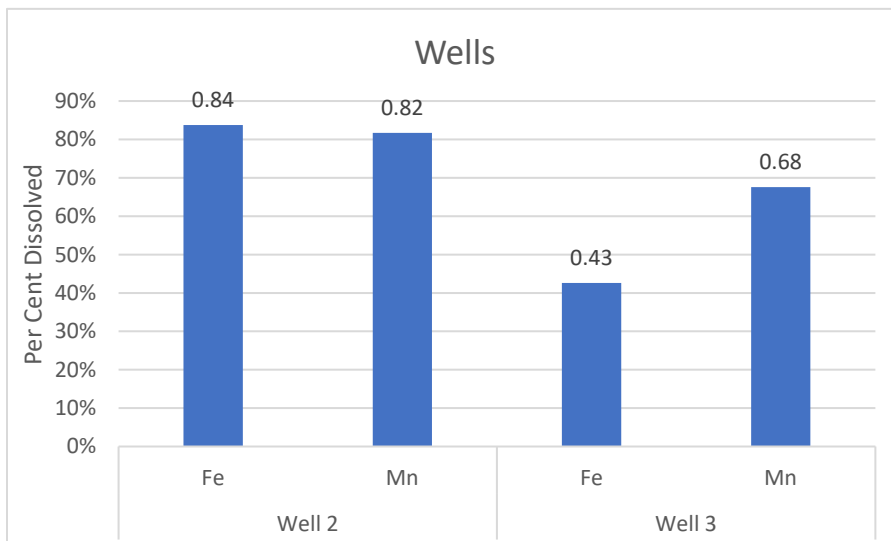

Figure 6. Percent of Iron and Manganese in Dissolved Form in Wells 2 and 3

**Attachment 4 Sample Station Iron
Concentration and Proportional Metal in
Dissolved Form**

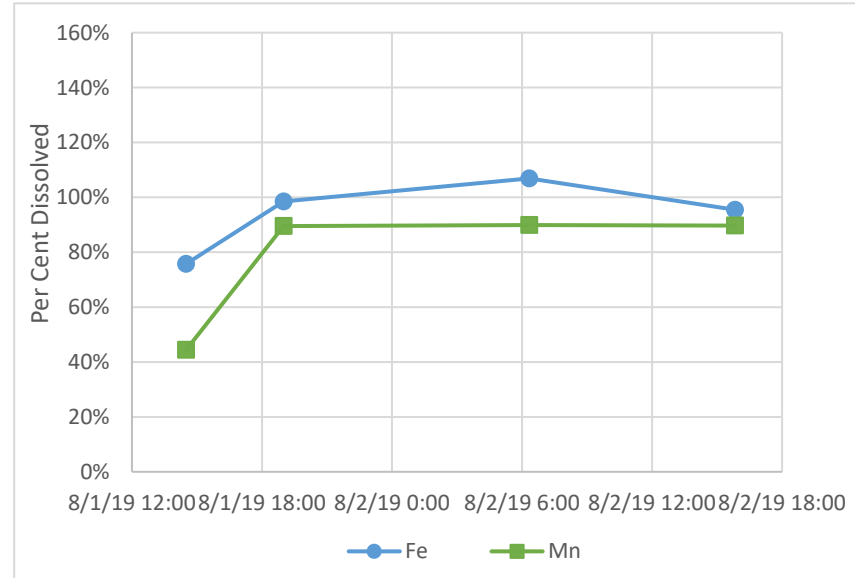
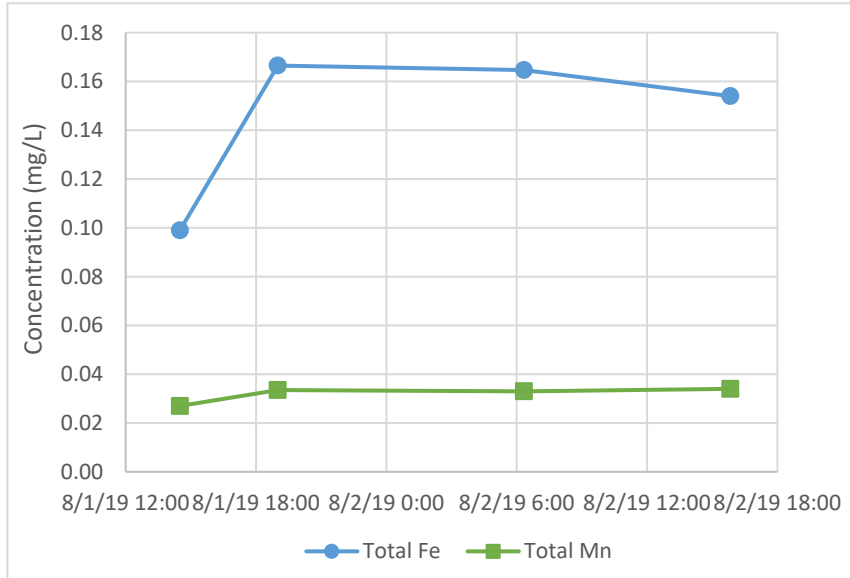

Figure 1: Iron and Manganese Data for Sample Station 1: 126 Mainprize Crescent, Mount Albert

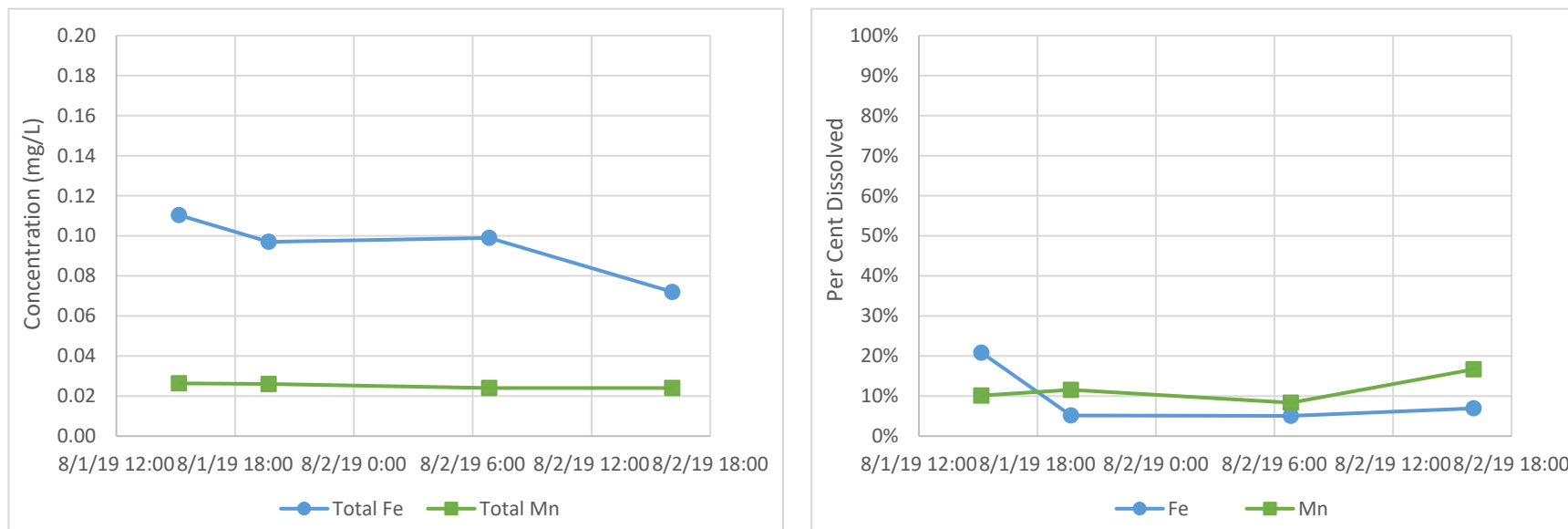

Figure 2: Iron and Manganese Data for Sample Station 2: 19451 Centre St, Mount Albert

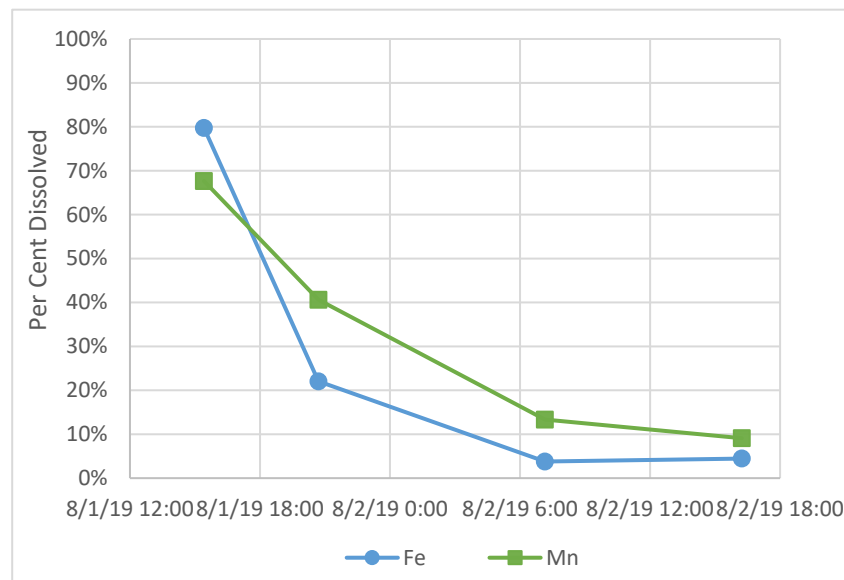
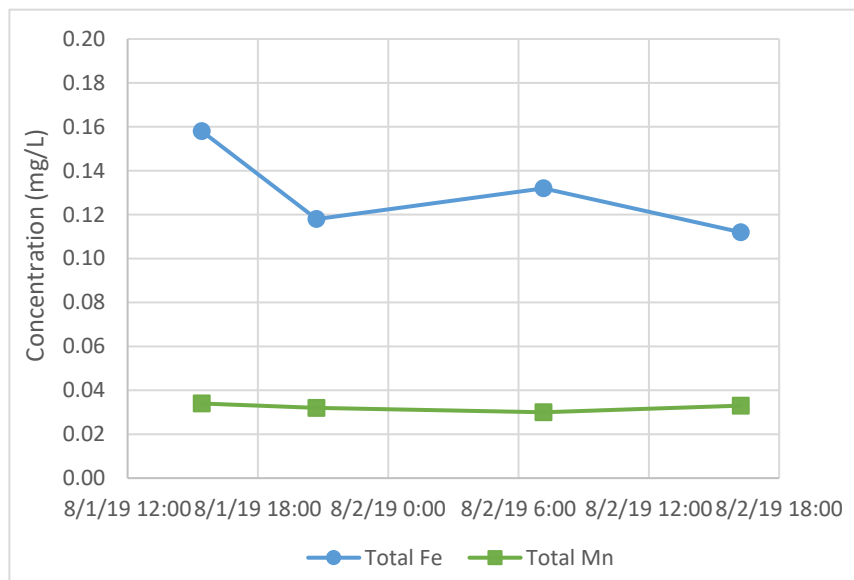

Figure 3: Iron and Manganese Data for Sample Station 3: 405 King St E. Mount Albert

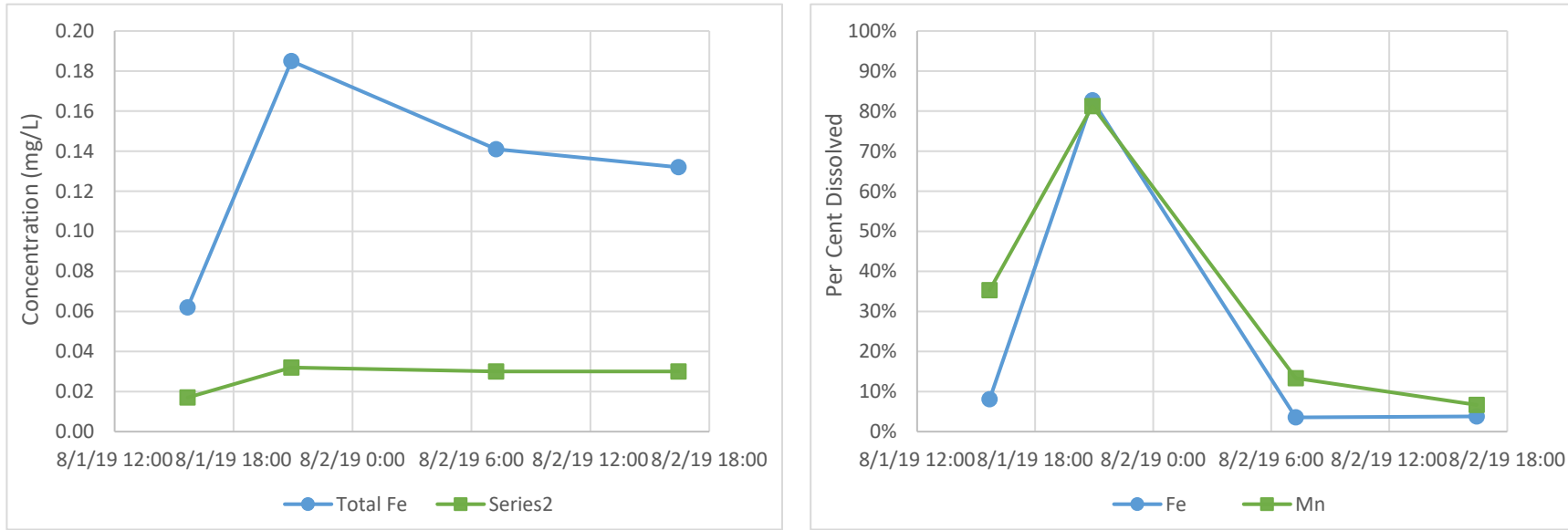

Figure 4: Iron and Manganese Data for Sample Station 4: 74 Manor Glen Crescent, Mount Albert

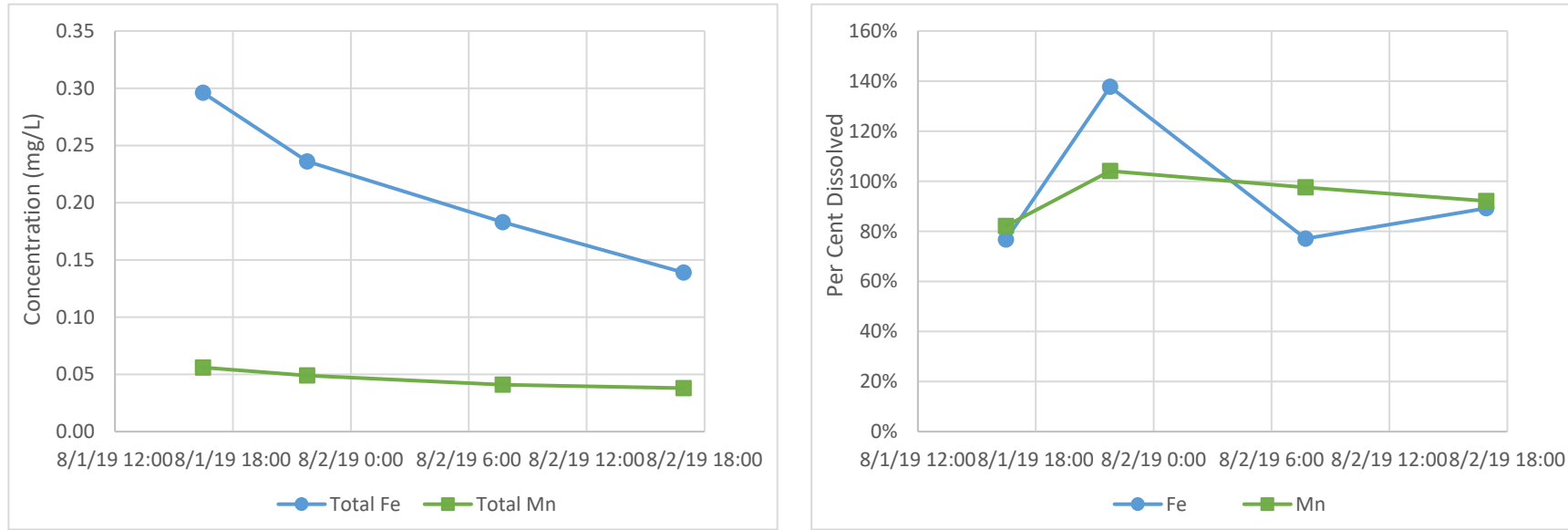

Figure 5: Iron and Manganese Data for Sample Station 5: Millennium Park at King St and Albert St, Mount Albert

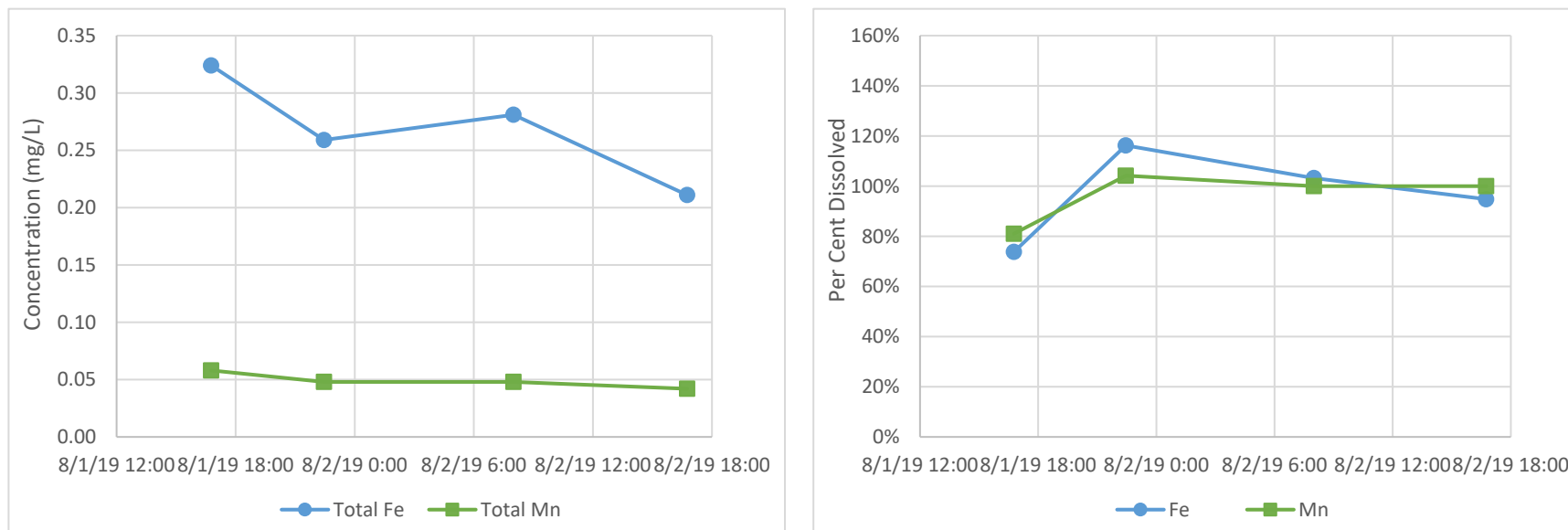

Figure 6: Iron and Manganese Data for Sample Station 6: 5517 Mount Albert Road, Mount Albert

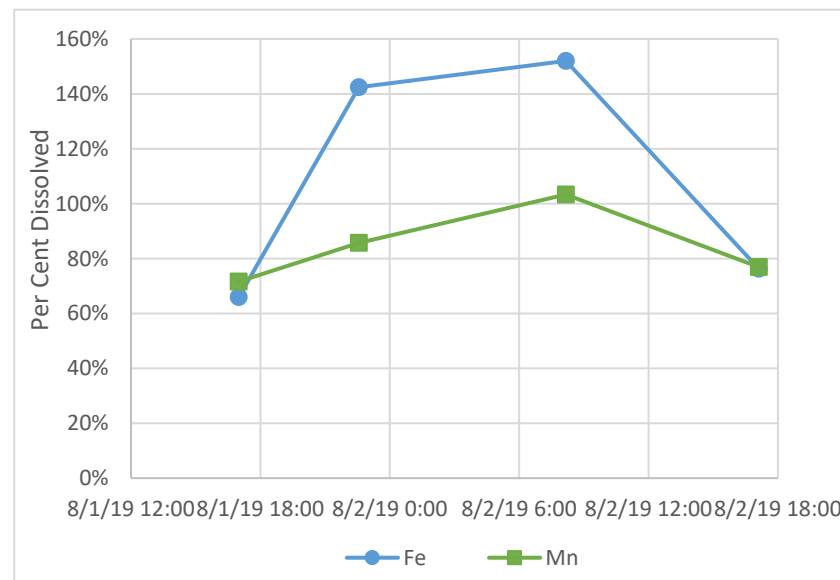
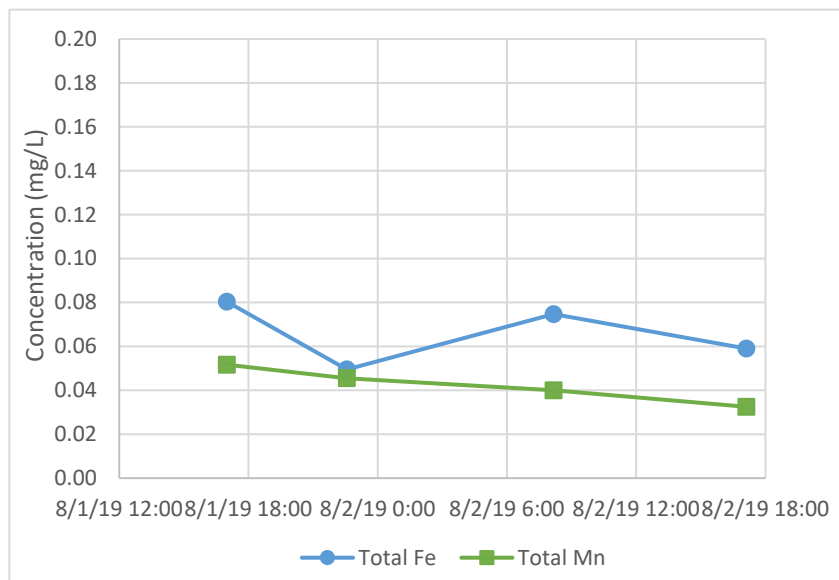

Figure 7: Iron and Manganese Data for Sample Station 7: 18855 Centre St, Mount Albert

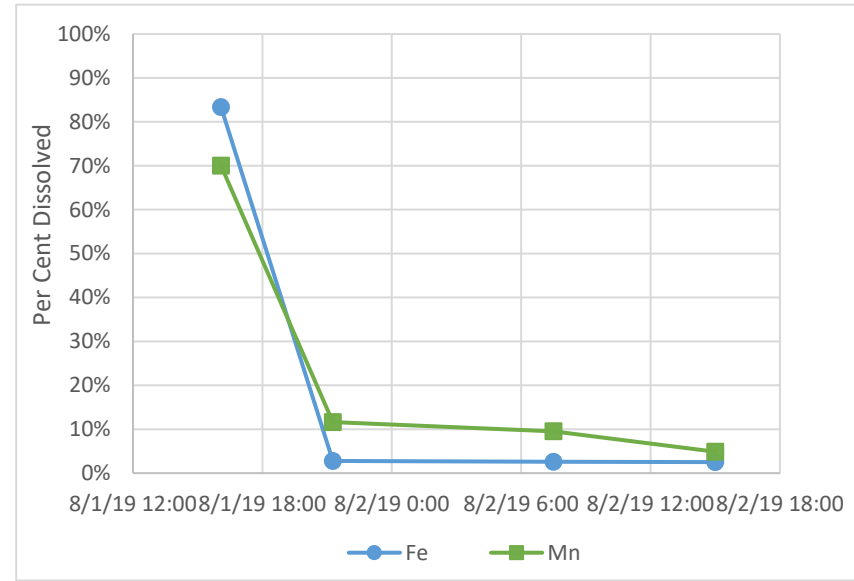
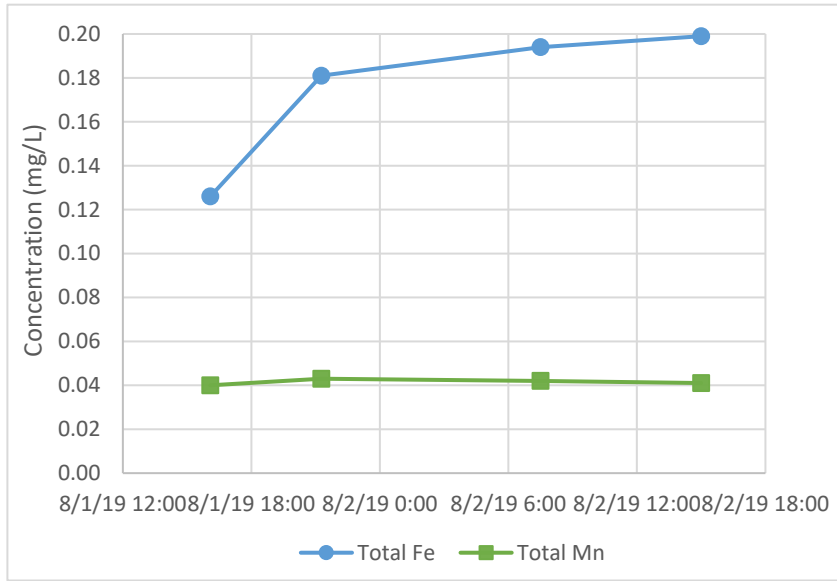

Figure 8: Iron and Manganese Data for Sample Station 8: Elevated Tank on 9th Line

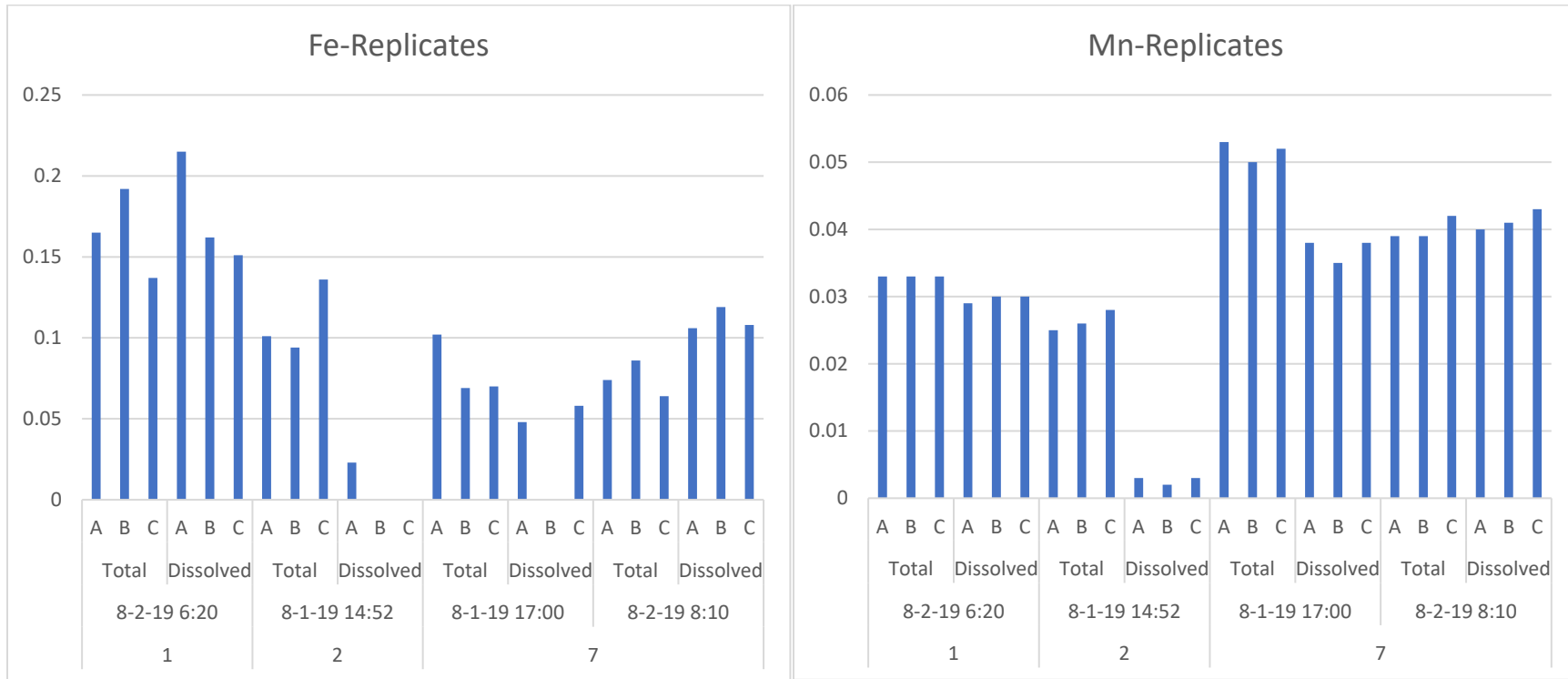

Figure 9. Iron and Manganese Replicate Data

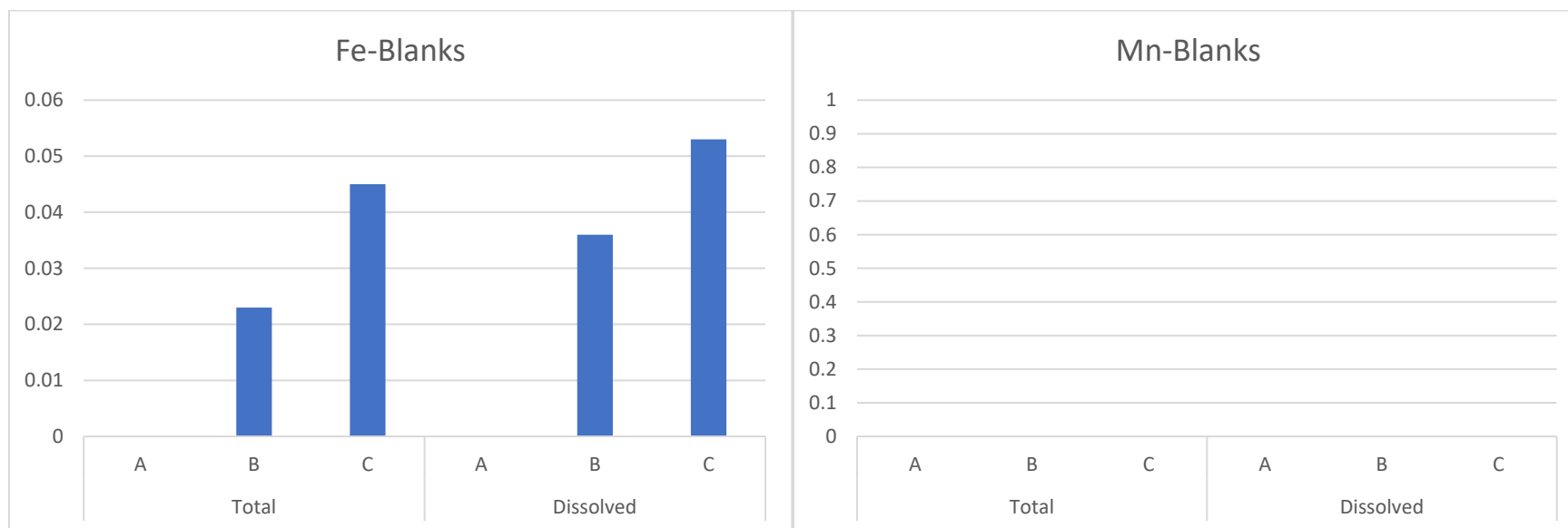

Figure 10. Iron and Manganese Blank Data

Attachment 5 Lab Quality Assurance Program Results

Quality Assurance

CLIENT NAME: JACOBS
PROJECT: CE731500 A.PN.OE.03.02
SAMPLING SITE:

AGAT WORK ORDER: 19T502022
ATTENTION TO: Dave Scott
SAMPLED BY:

Water Analysis

RPT Date: Aug 15, 2019			DUPLICATE				Method Blank	REFERENCE MATERIAL			METHOD BLANK SPIKE			MATRIX SPIKE		
PARAMETER	Batch	Sample Id	Dup #1	Dup #2	RPD	Measured Value		Acceptable Limits		Recovery	Acceptable Limits		Recovery	Acceptable Limits		
								Lower	Upper		Lower	Upper		Lower	Upper	

Inorganic Chemistry

Total Iron	416623	416623	0.099	0.088	11.8%	< 0.010	106%	90%	110%	110%	90%	110%	116%	70%	130%
Total Manganese	416623	416623	0.027	0.027	0.0%	< 0.002	103%	90%	110%	103%	90%	110%	99%	70%	130%
Total Silicon	416623	416623	10.8	10.2	5.7%	< 0.05	107%	90%	110%	109%	90%	110%	90%	70%	130%

Inorganic Chemistry

Total Iron	416663	416663	0.070	0.062	12.1%	< 0.010	102%	90%	110%	99%	90%	110%	92%	70%	130%
Total Manganese	416663	416663	0.052	0.053	1.9%	< 0.002	106%	90%	110%	106%	90%	110%	106%	70%	130%
Total Silicon	416663	416663	12.5	10.9	13.7%	< 0.05	101%	90%	110%	95%	90%	110%	71%	70%	130%

Inorganic Chemistry

Total Iron	416693	416693	0.165	0.155	6.3%	< 0.010	108%	90%	110%	101%	90%	110%	122%	70%	130%
Total Manganese	416693	416693	0.033	0.033	0.0%	< 0.002	107%	90%	110%	102%	90%	110%	98%	70%	130%
Total Silicon	416693	416693	12.1	12.7	4.8%	< 0.05	100%	90%	110%	95%	90%	110%	100%	70%	130%

Inorganic Chemistry

Total Iron	416755	416755	0.064	0.053	17.3%	< 0.010	95%	90%	110%	107%	90%	110%	121%	70%	130%
Total Manganese	416755	416755	0.042	0.043	3.5%	< 0.002	109%	90%	110%	109%	90%	110%	107%	70%	130%
Total Silicon	416755	416755	13.3	13.8	3.6%	< 0.05	97%	90%	110%	100%	90%	110%	100%	70%	130%

Inorganic Chemistry

Total Iron	416794	416794	0.108	0.097	10.3%	< 0.010	94%	90%	110%	108%	90%	110%	100%	70%	130%
Total Manganese	416794	416794	0.037	0.038	2.8%	< 0.002	109%	90%	110%	110%	90%	110%	96%	70%	130%
Total Silicon	416794	416794	13.1	13.6	4.2%	< 0.05	97%	90%	110%	101%	90%	110%	100%	70%	130%

Certified By: _____

Divine Basily